

RINGSPANN	Installation and Operating Instructions for Belleville Spring Torque Limiters, Series RT – Sizes 95, 120, 140 and 170			E 04.687e	
issue 19.03.2009	Version: 03	gez.: FR	gepr.: TM	Seitenzahl: 8	Seite: 1

IMPORTANT

Please read these instructions carefully before installing and operating the product. Your particular attention is drawn to the notes on safety.

These installation and operating instructions are valid on condition that the product meets the selection criteria for its proper use. Selection and design of the product is not the subject of these installation and operating instructions.

Disregarding or misinterpreting these installation and operating instructions invalidates any product liability or guarantee by RINGSPANN; the same applies if the product is taken apart or changed.

These installation and operating instructions should be kept in a safe place and should accompany the product if it is passed on to others – either on its own or as part of a machine – to make it accessible to the user.

SAFETY NOTICE

- Installation and operation of this product should only be carried out by skilled personnel.
- Repairs may only be carried out by the manufacturer or accredited RINGSPANN agents.
- If a malfunction is indicated, the product or the machine into which it is installed, should be stopped immediately and either RINGSPANN or an accredited RINGSPANN agent should be informed.
- Switch off the power supply before commencing work on electrical components.
- Rotating machine elements must be protected by the purchaser to prevent accidental contact.
- Supplies abroad are subject to the safety laws prevailing in those countries.



RINGSPANN GmbH

Schaberweg 30-34
61348 Bad Homburg
Germany

Telephone +49 6172 275-0
Telefax +49 6172 275-275

www.ringspann.com
mailbox@ringspann.com

RINGSPANN	Installation and Operating Instructions for Belleville Spring Torque Limiters, Series RT – Sizes 95, 120, 140 and 170			E 04.687e	
	issue 19.03.2009	Version: 03	gez.: FR	gepr.: TM	Seitenzahl: 8 Seite: 2

Contents

1. General comments
2. Design and function
3. Parts list
4. Condition on delivery
5. Adjusting the glidebush length
6. Boring the hub
7. Dismantling and re-assembly of the Belleville spring torque limiter
8. Torque setting
9. Table for torque setting
10. Installing onto the shaft
11. Removal from the shaft
12. Maintenance
13. Measuring wear on friction linings

1. General Comments

Belleville spring torque limiters of the series RT are safety units. They are used whenever machines or installations are to be protected against damage caused by overload.

2. Design and Function

During normal operation the Belleville spring torque limiter transmits torque from the connecting part (e. g. chain wheel) via friction linings to the hub.

When an overload occurs, i. e. when the load torque exceeds its pre-set limit (limit torque), the connecting part slips. This results in a relative movement between the connecting part and the hub. During the slipping movement kinetic energy is transformed into frictional heat. The limit torque continues to be transmitted. The maximum permissible temperature of the torque limiter is 200 °C.

When the load torque falls below the pre-set limit, connecting part and hub rotate again at the same speed.

The limit torque is set via the adjusting nut with the hexagonal screws and the pre-load of the plate springs. See also chapter 8, '*Torque setting*'.

Sliding movements result in wear on the friction linings. It may therefore be necessary to adjust the pre-loading of the plate springs.

3. Parts list

Pos.	Bezeichnung
1	hub
2	grub screw
3	friction lining
4	glidebush
5	pressure ring
6	belleville springs
7	locking plate
8	hex. screw
9	adjusting nut

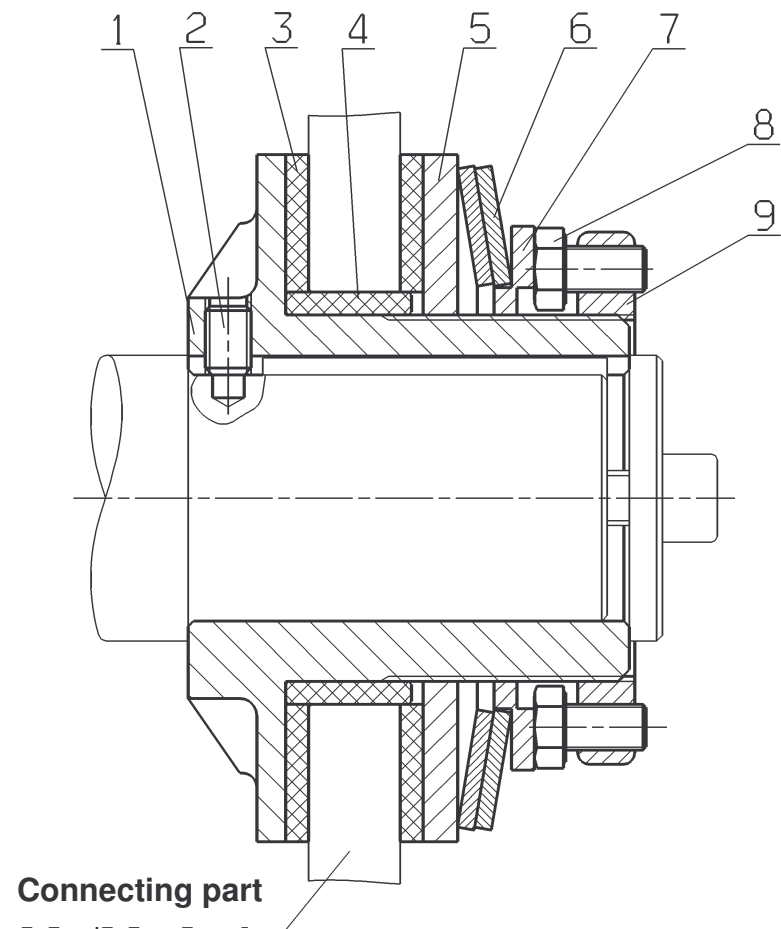

4. Condition on delivery

The belleville spring torque limiter is supplied as requested on the order, either

- finished bored or unbored,
- including glidebush,
- with the number of plate springs correctly arranged, according to the torque range requested,
- without torque setting or with torque setting to the limit torque specified (only finished bored and with connecting part, e. g. chain wheel).

It is:

- pre-assembled,
- surface-protected
- wrapped in packing paper

5. Adjusting the glidebush length

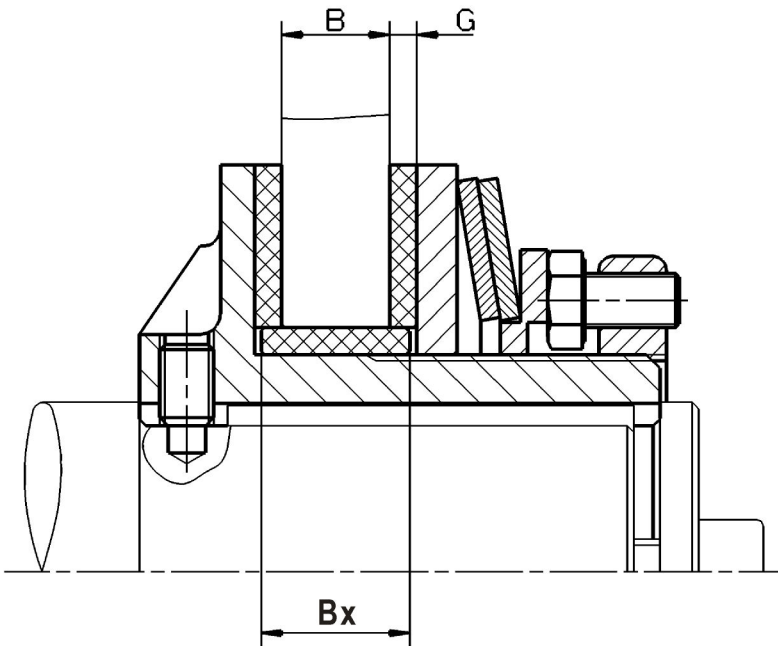

The length of the glidebush (4) is designed so that it centres both friction linings (3), permitting wear.

Before the connecting part can be fitted, the total length B_x of the glidebushes must be checked. Depending on installation width B of the connecting part, either one or two glidebushes may be needed.

The following formula is used to calculate the required total length B_x of the glidebushes:

$$B_x = B + G + 1,5.$$

RT	G	$B_{x_{std}}$	B_{max}
Size	[mm]	[mm]	[mm]
95	4	16	15
120	4	21	20
140	4	22	20
170	4,6	24	20

The supplied glidebushes have length $B_{x_{std}}$.

If the required total length of the glidebush is less than $B_{x_{std}}$, one glidebush will be sufficient, and this can be shortened, if necessary.

If the required total length of the glidebush is greater than $B_{x_{std}}$, then two glidebushes will be required. These can be shortened, if necessary. We recommend that both glidebushes are shortened equally.

RINGSPANN	Installation and Operating Instructions for Belleville Spring Torque Limiters, Series RT – Sizes 95, 120, 140 and 170		E 04.687e	
issue 19.03.2009	Version: 03	gez.: FR	gepr.: TM	Seitenzahl: 8 Seite: 5

6. Boring the hub

In order to bore the hub, the plate spring torque limiter must be completely dismantled. The maximum permissible bore diameter must be observed, as well as the shape of the keyway and the permissible runout.

Dismantling and re-assembly: see chapter 7: 'Dismantling and re-assembly of the belleville spring torque limiter'

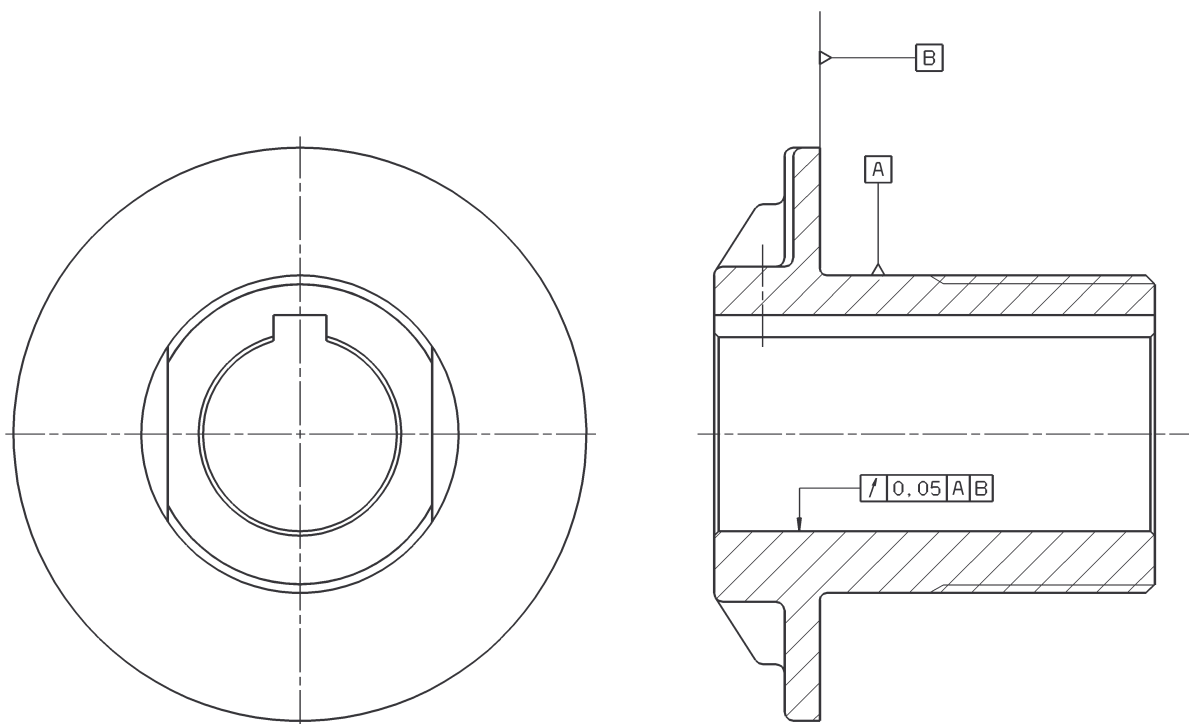

7. Dismantling and re-assembly of the Belleville spring torque limiter

1. Unscrew the adjusting nut (9)
2. Remove locking plate (7), plate springs (6), and pressure ring (5) from the hub. Take care with the coating of the plate springs. This is important for the re-assembly process later on.
3. Take off friction linings (3), glidebush (4) and, if applicable, the connecting part.

Re-assembly is done in reverse order.

RINGSPANN	Installation and Operating Instructions for Belleville Spring Torque Limiters, Series RT – Sizes 95, 120, 140 and 170			E 04.687e	
issue 19.03.2009	Version: 03	gez.: FR	gepr.: TM	Seitenzahl: 8	Seite: 6

8. Torque Setting



Warning:
Torque setting can only be carried out when the connecting part has been fitted.

The tool required for the setting is a open-ended spanner.

1. Screw in the adjusting nut (9) by hand until it is located completely against the plate springs (6). The hexagonal screws must be fully screwed in.
2. The setting of the required limit torque is carried out according to the following scheme:
 - a) Look in chapter 9. 'Table for torque setting' in the appropriate column under "for type RT" for the size supplied.
 - b) Find the respective limit torque or the nearest value from this column
 - c) take the appropriate number of 60° screw turns in the same row of the outer left column.

example: The Belleville Spring Torque Limiter RT 95.1 will be adjusted on aprox. 86 Nm when the screws will be turned by 4 • 60° screw turns = 240° turn.

3. Unscrew all the hexagonal screws (8) from the adjusting nut (9) by the respective number of screw turns required. This causes the plate springs to become pre-loaded.

Tip: The table values represent standard values. Due to variations in the friction value and machining tolerances of the plate springs and the manual location of the adjusting nut (9) obvious deviations of the limit torque from the nominal value occur. We therefore recommend a running in procedure during which the slipping at the required limit torque is checked. If necessary, correct the limit torque by turning the hexagonal screws (8). All the hexagonal screws must always be adjusted by the same number of turns.



Warning!
The temperature of the torque limiter must not exceed 200°C during running-in and later during operation!

9. Table for torque setting

Number of 60° screw turns	Limit torque in Nm							
	for type RT							
	95.1	95.2	120.1	120.2	140.1	140.2	170.1	170.2
0	9	14	11	16	40	43	22	32
1	22	32	–	–	–	–	–	–
2	41	57	25	48	110	125	80	200
3	62	84	–	–	–	–	–	–
4	86	116	59	116	208	280	190	409
5	109	160	–	–	–	–	–	–
6	133	210	105	225	287	420	310	597
7	156	255	–	–	–	–	–	–
8	178	300	160	315	360	560	431	784
9	–	328	–	–	–	–	–	–
10	–	340	225	389	427	690	530	950
12	–	–	279	453	490	810	620	1100
14	–	–	319	505	537	907	690	1237
16	–	–	350	548	580	1000	750	1360
18	–	–	–	582	620	1077	812	1480
20	–	–	–	612	–	1130	845	1596
22	–	–	–	640	–	1170	867	1700
24	–	–	–	–	–	1200	890	1750

10. Installing onto the shaft

Draw the Belleville spring torque limiter onto the shaft. The bore is made to tolerance H7. Keyway as per DIN 6885, page 1 or page 3. Tolerance of the keyway width is JS9.



Warning:
Do not use a hammer for mounting the Belleville spring torque limiter!

The Belleville spring torque limiter with insert connecting part on the wave axially position and axially secure. This can be done either with the supplied grub screw (2) by drilling or with a retaining plate. Both possibilities are illustrated in the drawing in chapter 3. 'Parts list'.



Warning:
Over the connecting part no bending moment may be led!

11. Removal from the shaft

Draw the Belleville spring torque limiter off the hub.



Warning:
Do not use a hammer for pushing the Belleville spring torque limiter off the shaft!

12. Maintenance

Belleville spring torque limiters normally do not require maintenance. However, they should be subject to inspections at regular intervals during operation.

The following should be noted:

1. are the friction linings worn (see also chapter 13. “*Measuring wear on friction linings*”) - and
2. is the Belleville spring torque limiter and the surrounding area free from oil and grease?

If the friction linings (3) are worn, the pre-load of the plate springs (6) must be adjusted.

13. Measuring wear on friction linings

Friction linings (3) are subjected to natural wear with each sliding movement (see also chapter 12. ‘*Maintenance: ‘adjustment*’). The friction linings become thinner. The design of the torque limiter permits a maximum degree of friction wear. This must be checked at regular intervals. Both friction linings must be replaced when the maximum limit of friction wear has been reached.

Wear is calculated as follows:

- Measure installation width B
- Calculate dimension X according to formula $X = B + (G \times 2)$ (take G from table)
- Measure dimension Y
- Calculate wear using formula $V = X - Y$.

If V is smaller than V_{max} , then both friction linings can continue to be used.

If V is greater or equal to V_{max} , then **both** friction linings **must** be replaced.

RT	G	V_{max}
Size	[mm]	[mm]
95	4	2,5
120	4	2,5
140	4	2,5
170	4,6	3,1

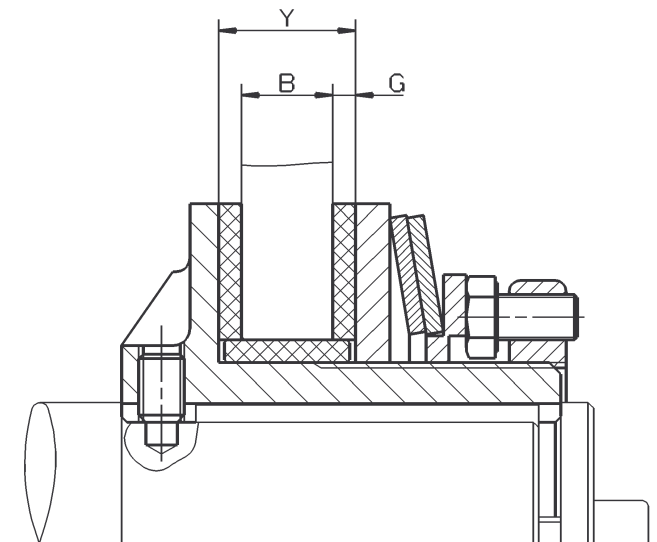

Warning!

If wear V is greater than V_{max} , the limit torque becomes very low. The glidebush (4) is jammed between hub (1) and pressure ring (5). The effect of the force of the plate spring is no longer acting fully on the friction linings (3) and the connecting part.