

# Cone Clamping Elements RLK 133

centres the hub to the shaft  
short axial width with fixed backstop point

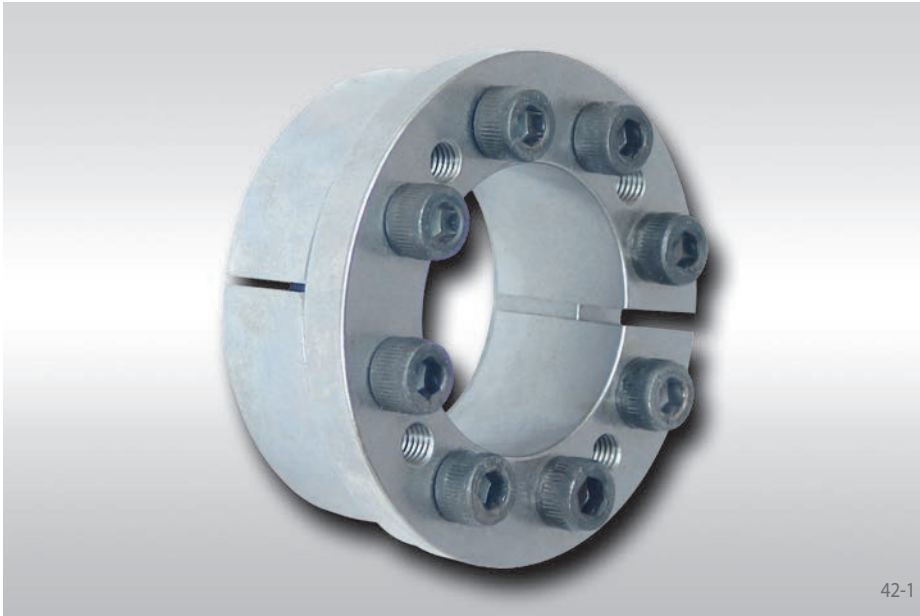

## Features

- Centres the shaft to the hub
- Short axial width
- No axial displacement between hub and shaft during clamping procedure due to fixed backstop point
- Transmissible torque of 350 Nm up to 51 500 Nm
- For shaft diameters between 20 mm and 200 mm

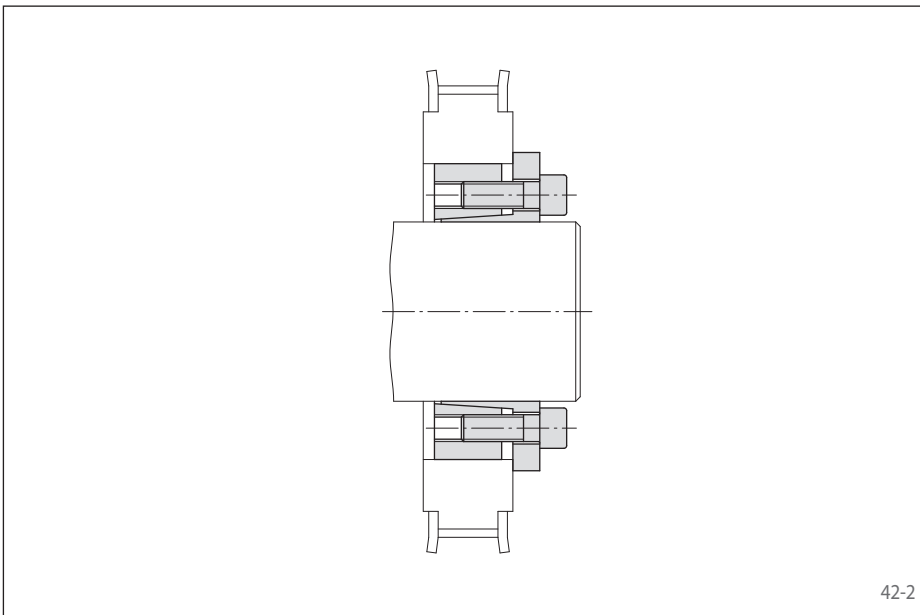

## Application example

Backlash free connection of a timing belt pulley to the drive shaft with a Cone Clamping Element RLK 133. Due to the fixed backstop point, the timing belt pulley is not displaced axially during clamping. The Cone Clamping Element also centres the timing belt pulley to the shaft. The compact Cone Clamping Element is a cost-efficient solution especially for applications with low space requirements.

## Transmissible torques and axial forces

The transmissible torques or axial forces listed on the following page are subject to the following tolerances, surface characteristics and material requirements. Please contact us in the case of deviations.

### Tolerances

- h8 for shaft diameter d
- H8 for hub bore D

### Surfaces

Average surface roughness at the contact surfaces between the shaft and the hub bore:  
 $R_z = 10 \dots 25 \mu\text{m}$ .

### Materials

The following apply to the shaft and the hub:

- E-module  $\geq 170 \text{ kN/mm}^2$

## Installation

Please request our installation and operating instructions for Cone Clamping Elements RLK 133.

## Simultaneous transmission of torque and axial force

The transmissible torques M which are shown in the tables apply for axial forces  $F = 0 \text{ kN}$  and conversely, the indicated axial forces F apply to torques  $M = 0 \text{ Nm}$ . If torque and axial force are to be transmitted simultaneously, the transmissible torque and the transmissible axial force are reduced. Please refer to the technical points on pages 72 and 73.

## Example for ordering

Cone Clamping Element RLK 133 for shaft diameter  $d = 100 \text{ mm}$ :

- RLK 133, size 100 x 145  
Article number 4204-100301-000000

# Cone Clamping Elements RLK 133

centres the hub to the shaft  
short axial width with fixed backstop point

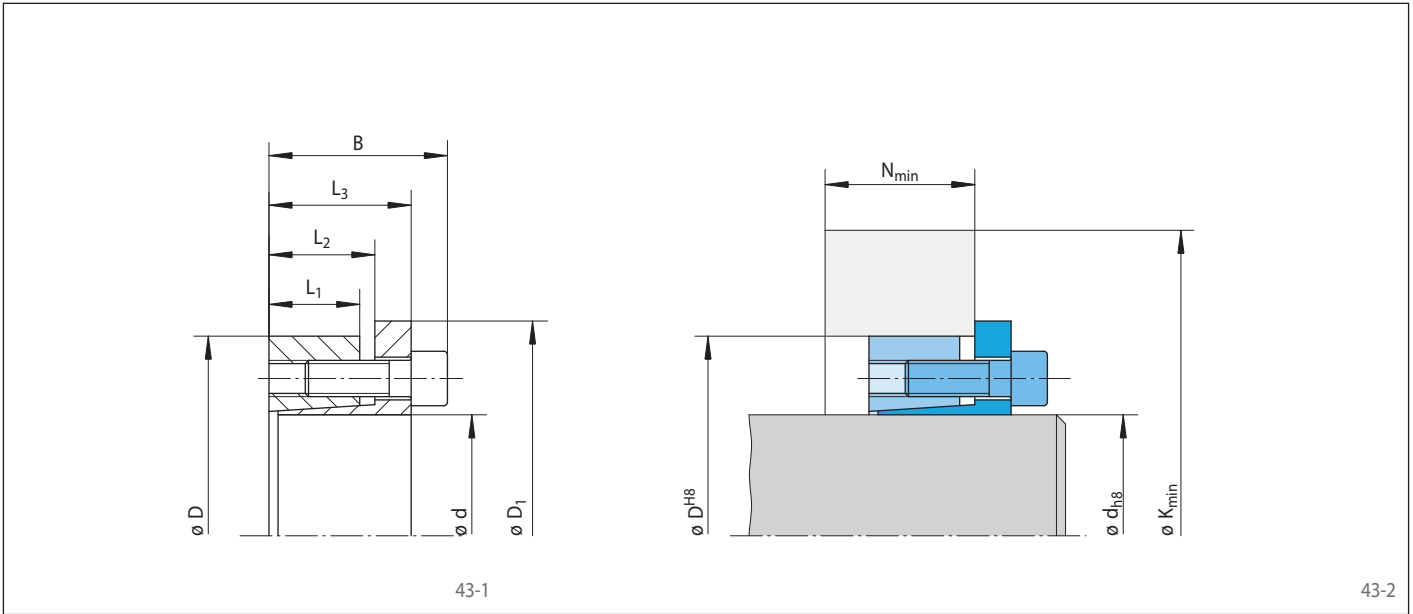

Dimensions													Technical Data										Article number
Size		D <sub>1</sub> mm	B mm	L <sub>1</sub> mm	L <sub>2</sub> mm	L <sub>3</sub> mm	Yield strength R <sub>e</sub> of the hub material [N/mm <sup>2</sup> ]						Transmissible torque or axial force		Contact pressure at		Clamping screws			Weight kg			
d mm	D mm						200	320	500	K <sub>min</sub> mm	N <sub>min</sub> mm	K <sub>min</sub> mm	N <sub>min</sub> mm	K <sub>min</sub> mm	N <sub>min</sub> mm	M Nm	F kN	Shaft P <sub>W</sub> N/mm <sup>2</sup>	Hub P <sub>N</sub> N/mm <sup>2</sup>		Tightening torque M <sub>5</sub> Nm	Number	
20	47	53	34	17	22	28	96	30	74	24	63	21	350	35	277	118	17,4	6	M 6	20	0,3	4204-020301-000000	
22	47	53	34	17	22	28	96	30	74	24	63	21	390	35	252	118	17,4	6	M 6	20	0,3	4204-022301-000000	
24	50	56	34	17	22	28	96	29	76	24	66	21	430	35	231	111	17,4	6	M 6	20	0,3	4204-024301-000000	
25	50	56	34	17	22	28	96	29	76	24	66	21	440	35	222	111	17,4	6	M 6	20	0,3	4204-025301-000000	
28	55	62	34	17	22	28	98	28	80	24	70	21	500	35	198	101	17,4	6	M 6	20	0,4	4204-028301-000000	
30	55	62	34	17	22	28	98	28	80	24	70	21	530	35	185	101	17,4	6	M 6	20	0,4	4204-030301-000000	
32	60	69	34	17	22	28	117	32	93	26	80	22	760	47	231	123	17,4	8	M 6	20	0,4	4204-032301-000000	
35	60	69	34	17	22	28	117	32	93	26	80	22	830	47	211	123	17,4	8	M 6	20	0,4	4204-035301-000000	
38	65	72	34	17	22	28	119	31	97	25	85	22	900	47	194	114	17,4	8	M 6	20	0,5	4204-038301-000000	
40	65	72	34	17	22	28	119	31	97	25	85	22	940	47	185	114	17,4	8	M 6	20	0,4	4204-040301-000000	
42	75	84	41	20	25	33	165	43	127	33	106	28	1800	86	273	153	42,2	8	M 8	25	0,8	4204-042301-000000	
45	75	84	41	20	25	33	165	43	127	33	106	28	1950	86	255	153	42,2	8	M 8	25	0,7	4204-045301-000000	
48	80	89	41	20	24	33	165	42	130	33	111	28	2050	86	239	143	42,2	8	M 8	25	0,8	4204-048301-000000	
50	80	89	41	20	24	33	165	42	130	33	111	28	2150	86	229	143	42,2	8	M 8	25	0,8	4204-050301-000000	
55	85	91	41	20	24	33	166	41	133	32	115	28	2350	86	208	135	42,2	8	M 8	25	0,8	4204-055301-000000	
60	90	99	41	20	24	33	168	40	137	32	120	28	2600	86	191	128	42,2	8	M 8	25	0,9	4204-060301-000000	
65	95	104	41	20	24	33	171	39	141	32	124	28	2800	86	176	121	42,2	8	M 8	25	0,9	4204-065301-000000	
70	110	119	50	24	29	40	213	50	172	40	149	34	4800	140	215	137	83,0	8	M 10	30	1,7	4204-070301-000000	
75	115	124	50	24	29	40	215	49	176	40	153	34	5100	140	201	131	83,0	8	M 10	30	1,8	4204-075301-000000	
80	120	129	50	24	29	40	218	49	179	39	158	34	5400	140	188	126	83,0	8	M 10	30	1,9	4204-080301-000000	
85	125	134	50	24	29	40	246	55	198	43	172	36	7200	170	221	151	83,0	10	M 10	30	2,0	4204-085301-000000	
90	130	139	50	24	29	40	248	54	202	42	176	36	7600	170	209	145	83,0	10	M 10	30	2,1	4204-090301-000000	
95	135	144	50	24	29	40	250	53	206	42	180	36	8100	170	198	140	83,0	10	M 10	30	2,2	4204-095301-000000	
100	145	154	56	26	31	44	269	57	221	45	194	39	10000	200	204	141	144,0	8	M 12	30	2,8	4204-100301-000000	
110	155	164	56	26	31	44	274	56	229	45	203	38	11000	200	186	132	144,0	8	M 12	30	3,0	4204-110301-000000	
120	165	174	56	26	31	44	295	59	246	47	218	40	13500	220	191	139	144,0	9	M 12	30	3,4	4204-120301-000000	
130	180	189	64	34	39	52	326	71	269	57	237	49	19500	300	180	130	144,0	12	M 12	30	5,1	4204-130301-000000	
140	190	199	68	34	39	54	336	71	280	57	248	49	21500	310	172	127	229,0	9	M 14	40	5,3	4204-140301-000000	
150	200	209	68	34	39	54	358	74	298	59	263	50	25500	340	178	134	229,0	10	M 14	40	5,6	4204-150301-000000	
160	210	219	68	34	39	54	395	81	325	63	284	53	33000	410	200	153	229,0	12	M 14	40	6,0	4204-160301-000000	
170	225	234	78	44	49	64	381	83	321	68	286	60	35000	410	146	110	229,0	12	M 14	40	8,2	4204-170301-000000	
180	235	244	78	44	49	64	387	82	329	68	295	59	37000	410	138	106	229,0	12	M 14	40	8,6	4204-180301-000000	
190	250	259	78	44	49	64	435	91	365	73	324	63	48500	510	163	124	229,0	15	M 14	40	10,0	4204-190301-000000	
200	260	269	78	44	49	64	441	90	373	73	333	63	51500	510	155	119	229,0	15	M 14	40	10,4	4204-200301-000000	