

TECNAMIC

Dynamic Drive Technology

COMPACT CATALOGUE COUPLINGS



A man with a beard and brown hair, wearing a blue and black plaid shirt, an orange safety vest with reflective stripes, and blue earmuffs, is holding a clipboard and a walkie-talkie. He is smiling slightly and looking towards the camera. The background is a blurred industrial setting.

“Get things moving
in a big way -
with the right drive.”

Norbert, 42, Foreman

Tecnamic is your partner for industrial applications in drives, control, and motion. With our extensive range of couplings, we are the ideal partner for technical trades - for original equipment manufacturers as well as end users nationally and internationally. Our technical support and engineering calculate and optimise entire drive systems. Accordingly, we can develop exact and individual solutions for our customers.

Our wide range of products allow us to supply solutions for all mechanical engineering applications with shaft connections. In addition we offer standard and customised solutions with a long service life and high operational reliability.

ELASTIC COUPLINGS



HABIX®

- Fail-safe plug-in / jaw coupling with flexible element (spider)
- Types: HWN (pre-drilled), HWT (for taper bushes), plus (backlash-free type)
- Sizes: 19 - 90
- Standard applications with normal requirements regarding torque and damping capabilities



HADEFLEX®

- Fail-safe plug-in / jaw coupling with flexible element (spider)
- Types: XW (pre-drilled), TX (for taper bushes), F (two- and three-part version)
- Sizes: 24 - 160
- Standard applications with normal requirements regarding torque and damping capabilities



HRC

- Fail-safe enclosed plug-in / jaw coupling with flexible element (spider)
- Types: B (pre-drilled), F and H (for taper bushes)
- Sizes: 70 - 280
- Applications with increased requirements on torque and damping capabilities



PEX

- Fail-safe plug-in / jaw coupling with flexible elements
- Types: A (three-part), B (two-part)
- Sizes: 58 - 250
- Applications with increased requirements on torque and damping capabilities



ORPEX®

- Fail-safe pin coupling with flexible elements
- Types: WN (grey cast iron), WS (steel)
- Sizes: 105 - 2000
- Applications with high requirements on transmitted torque and damping capabilities



FLEX

- Highly flexible tyre coupling
- Types: B (pre-drilled), F and H (for taper bushes)
- Sizes: 40 - 250
- Applications with increased requirements on damping capabilities and shaft compensation values

RIGID COUPLINGS



GEAR COUPLING GC

- Crowned toothed and greased gear coupling
- Sizes: 50 - 1000
- Applications with highest to maximum requirements regarding transmitted torque



MINI COUPLING

- Slotted backlash-free clamp coupling
- Types: MWK (clamp hub slotted), MWH (half-shells, sizes: 30 - 80)
- Sizes: 16 - 80
- Applications with low requirements on transmitted torque and damping capabilities
- Ideal for limited installation spaces.



CLAMP COUPLING

- Easy-to-assemble shaft connection
- Types: Slotted 1-piece and split 2-piece design in steel and stainless steel
- Sizes: 10 - 30
- Simple and easy-to-assemble shaft connections with no specific requirements on damping capabilities



CLAMP COUPLING DIN 115

- Easy-to-assemble shaft connection
- Sizes: 25 - 220
- Simple and easy-to-assemble shaft connections with no specific requirements on damping capabilities



FLANGE COUPLING DIN 116

- Easy-to-assemble and particularly robust shaft connection
- Sizes: 25 - 500
- Simple, particularly robust and easy-to-assemble shaft connections with no specific requirements on damping capabilities

FLEXIBLE COUPLINGS

HABIX® HWN/HWT
HABIX® PLUS HPN/HPK



HABIX®

TYPE HWN

The flexible Habix® coupling, type HWN, is a distortion-free jaw coupling with flexible elements for the torsionally flexible connection of shafts. The advantage of the all-round-machined Habix® couplings is the precision of the operating characteristic as well as the increased durability. Habix® couplings are distortion-free up to the breaking load of the cast iron transmission cam and insure a maximum of operational safety. The flexible element is available in white color with a hardness of 92 Shore A and in red color with a hardness of 98 Shore A. It is resistant against wear as well as against oil, ozone and ageing. The flexibility of the couplings absorbs efficiently shockloads, torsional vibrations and noises. The flexible element of the couplings has been designed to compensate radial, axial and angular movements between the coupling halves. By the fixed position of the flexible element its deformability in axial direction is free and no harmful axial forces may disturb the machine bearing even with changing torques. The flexible element of the Habix® coupling allows a permanent thermal load up to 80 °C. Even low temperatures up to -20 °C are allowed. The flexible Habix® coupling can easily be connected and does not require a high accuracy of the shaft alignment.

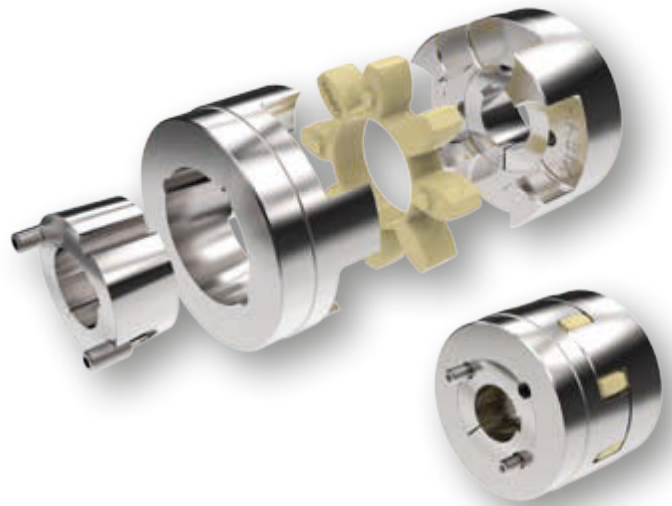

TYPE

- > Standard coupling HWN
- > Taper bush type HWT
- > Combined type standard/taper HWNT
- > Components can be combined as needed

TYPE HWT - WITH TAPER BUSH

The Habix® coupling type HWT joins the advantages of the flexible couplings with the advantages of the taper bush system: fast and easy installation for a torsionally flexible connection between shafts and compensation of shaft misalignments. The HWT types with the taper bush system have the advantage that there is a backlash-free and at the same time axial fixing of the shaft

even at bigger shaft tolerances. In addition the slide fit allows the axial alignment of the coupling. The exchange of the flexible element is possible by simply sliding the coupling halves in axial direction without removing the driving or driven machine. The field of application of the Habix® coupling is all the engineering industry wherever a safe connection between motor and driven machine is required.

TECHNICAL DATA

TYPE HWN/HWT

Size	Max. rotation speed rpm	Torque Nm			Torque Nm		
		nominal T_{KN}	max. T_{kmax}	changing T_{KW}	nominal T_{KN}	max. T_{kmax}	changing T_{KW}
		92° Shore A color white			98° Shore A color red		
19	19 000	10	20	2.6	17	34	4.4
24	14 000	35	70	9	60	120	16
28	11 800	95	190	25	160	320	42
38	9 500	190	380	49	325	650	85
42	8 000	265	530	69	450	900	117
48	7 100	310	620	81	525	1050	137
55	6 300	410	820	105	685	1370	178
65	5 600	625	1250	163	940	1880	245
75	4 750	1280	2560	333	1920	3840	499
90	3 750	2400	4800	624	3600	7200	936

> Torques for shaft fit with keyway

Size Δ	Max. shaft misalignment ²⁾		
	radial ¹⁾ $\Delta K_r / \text{mm}$	axial ¹⁾ $\Delta K_a / \text{mm}$	angular ¹⁾ $\Delta K_w / \text{degree}$
19	0.20	1.2	1.2
24	0.22	1.4	0.9
28	0.25	1.5	0.9
38	0.28	1.8	1.0
42	0.32	2.0	1.0
48	0.36	2.1	1.1
55	0.38	2.2	1.1
65	0.42	2.6	1.2
75	0.48	3.0	1.2
90	0.50	3.4	1.2

1) The values mentioned are valid for 1.500 rpm and may occur only separately. At multiple misalignments or higher speeds the values must be reduced (see page 7).

2) The values mentioned are valid for an ambient temperature of 30°C. At higher temperatures the values must be reduced.

TYPE HWN

WITH KEYWAY MOUNTING

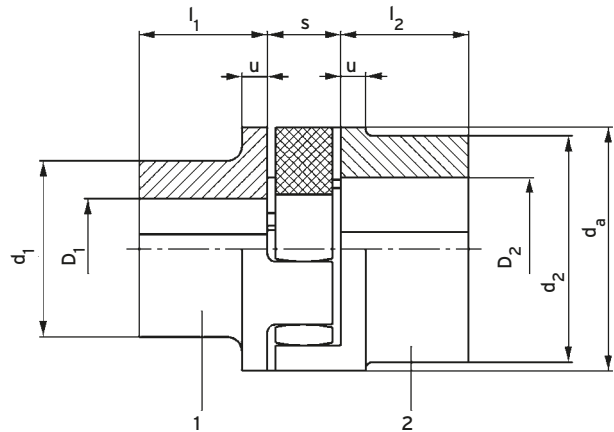

Size	Part 1				Part 2				da	u	s
	Pre. mm	max. mm	d ₁ mm	l ₁ mm	Pre. mm	max. mm	d ₂ mm	l ₂ mm			
19	-	19	32	25	17	24	39.5	25	40	5	16
24	-	24	40	30	22	28	48	30	55	6	18
28	-	28	48	35	26	38	64.5	35	65	7	20
38	10	38	66	45	36	45	78	45	80	8	24
42	12	42	75	50	40	55	94	50	95	10	26
48	13	48	85	56	46	60	104	56	105	11	28
55	18	55	98	65	53	70	118	65	120	13	30
65	20	65	115	75	63	75	134	75	135	14	35
75	28	75	135	85	73	90	158	85	160	16	40
90	38	90	160	100	88	100	180	100	200	19	45

Size	Weight / kg		Moments of inertia kgm ²	
	Part 1	Part 2	Part 1	Part 2
19	0.16	0.21	0.00003	0.00005
24	0.40	0.40	0.00011	0.00015
28	0.52	0.76	0.00024	0.00049
38	1.1	1.4	0.00087	0.0013
42	1.7	2.3	0.0018	0.0031
48	2.8	3.1	0.0031	0.0052
55	3.7	4.6	0.062	0.010
65	5.7	7.0	0.013	0.019
75	8.8	11	0.027	0.041
90	15	15	0.068	0.090

- > Drill holes H7 with keyway in accordance with DIN 6885/1; tolerance zone JS9 and set screws on the keyway; weight and moments of inertia valid for medium bore diameters
- > Coupling half materials: EN-GJL-250 (GG-25) in accordance with DIN EN 1561
- > Possible combination:
 - 1/1
 - 1/2
 - 2/2
- > Can also be combined with type HWT

TYPE HWT

FOR TAPER BUSH

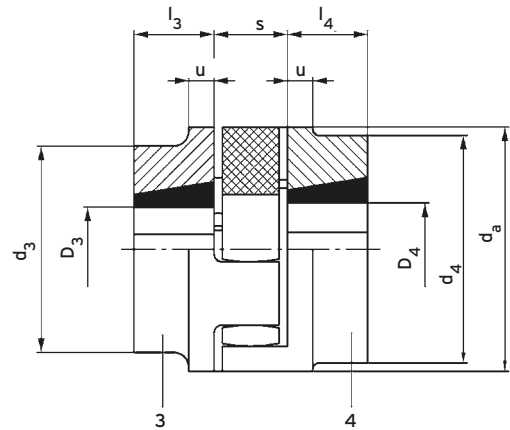

Size	Part 3					Part 4					da	u	s
	D ₃		Taper bush no.	d ₃	l ₃	D ₄		Taper bush no.	d ₄	l ₄			
	min. mm	max. mm				min. mm	max. mm						
19	-	-	-	-	-	-	-	-	-	-	40	5	16
24	10	25	1008	54.5	22	10	25	1008	54.5	22	55	6	18
28	10	28	1108	64.5	22	10	28	1108	64.5	22	65	7	20
38	10	28	1108	78	22	10	28	1108	78	22	80	8	24
42	14	42	1610	94	25	14	42	1610	94	25	95	10	26
48	14	42	1615	104	38	14	42	1615	104	38	105	11	28
55	14	50	2012	118	32	14	50	2012	118	32	120	13	30
65	14	50	2012	126	32	16	60	2517	134	45	135	14	35
75	16	60	2517	158	45	25	75	3020	158	51	160	16	40
90	25	75	3020	160	51	35	90	3535	180	89	200	19	45

Size	Weight kg		Moments of inertia kgm ²	
	Part 3	Part 4	Part 3	Part 4
19	-	-	-	-
24	0.39	0.39	0.00017	0.00017
28	0.55	0.55	0.00032	0.00032
38	0.86	0.86	0.00074	0.00074
42	1.4	1.4	0.0017	0.0017
48	2.5	2.5	0.0037	0.0037
55	2.7	2.7	0.0054	0.0054
65	3.4	4.8	0.0082	0.0012
75	6.8	7.3	0.023	0.026
90	9.5	16	0.044	0.081

- > Weight and moments of inertia valid for medium bore diameters inc. taper bushes
- > Coupling half materials:
EN-GJL-250 (GG-25) in accordance with DIN EN 1561
- > Possible combination:
3/3
3/4
4/4
- > Can also be combined with type HWN

TAPER BUSHES WITH KEYWAYS ACC. TO DIN 6885/1

TOLERANCE JS9



Taper bush no.	Bore \varnothing of available taper bushes											
	mm											
1008	10	11	12	14	16	18	19	20	22	24*	25*	
1108	10	11	12	14	16	18	19	20	22	24	25	28*
1610/ 1615	14	16	18	19	20	22	24	25	28	30	32	35
	38	40	42*									
2012	14	16	18	19	20	22	24	25	28	30	32	35
	38	40	42	45	48	50						
2517	16	18	19	20	22	24	25	28	30	32	35	38
	40	42	45	48	50	55	60					
3020	25	28	30	32	35	38	40	42	45	48	50	55
	60	65	70	75								
3535	35	38	40	42	45	48	50	55	60	65	70	75
	80	85	90									

* These bore holes are with flat keyway in accordance with DIN 6885/3.

ALLOWABLE MISALIGNMENTS

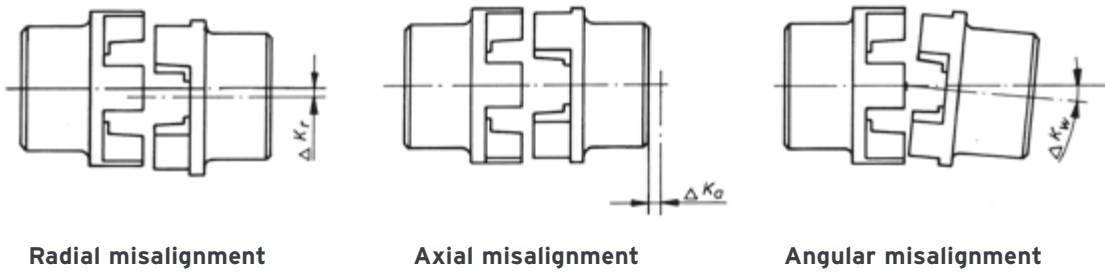

- Reduction of the allowable values of misalignment when the combination of misalignments occur or at other rotational speeds:

$$\frac{\Delta W_r}{\Delta K_r} + \frac{\Delta W_a}{\Delta K_a} + \frac{\Delta W_w}{\Delta K_w} \leq X$$

$\Delta K_{r/a/w}$ = allowable radial, axial or angular misalignment of the shafts resp. of the coupling halves

$\Delta W_{r/a/w}$ = measured radial, axial or angular misalignment of the shafts resp. of the coupling halves.

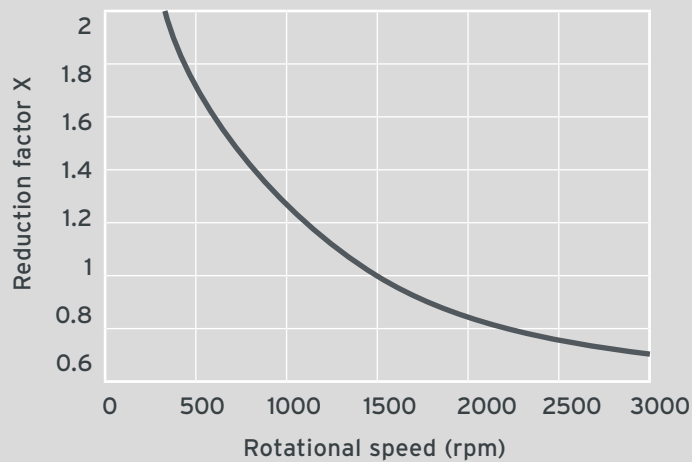

HABIX® PLUS

Habix®plus consist of two coupling hubs with curved jaws, which are produced with high concentricity. The precision rating is made of an extremely wear-resistant and temperature-resistant plastic. Up to size 48 the clutch is constructed of high-strength aluminum, from size 65 it is constructed of steel.

The equalizing element of the Habix®plus HPN or HPK coupling is the star. It transmits torque without backlash or vibration. The high-precision star insert defines the characteristics of the entire drive system.

Backlash is eliminated by the press fit of the star into the hubs. The Habix®plus HPN or HPK couplings has been designed to compensate radial, axial and angular movements.

The flexible element of the Habix®plus coupling allows a permanent thermal load up to 100°C or 120°C. Even low temperatures up to -30°C are allowed.

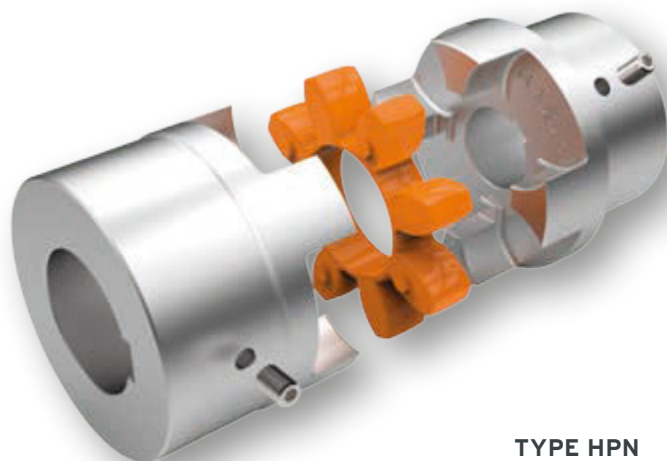

TYPE HPN

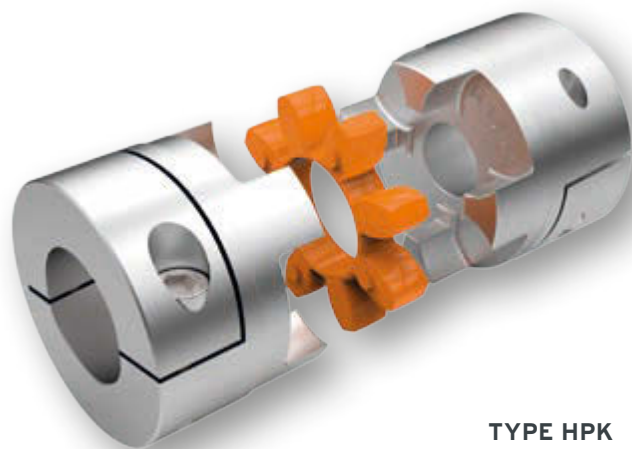

TYPE HPK

FEATURES

- > Cheap
- > High concentricity
- > Vibration-reducing
- > Electrically isolating
- > Pluggable

AREA OF APPLICATION

- > Servodrive technology
- > Machine tools
- > Packaging machinery
- > Automation systems
- > Printing machines
- > Control- and positioning technique
- > General mechanical engineering

TECHNICAL DATA

TYPE HPN/HPK

Size	Speed rpm	Torque Nm		Torque Nm	
		nominal T	max. T	nominal T	max. T
		98 Shore A color orange		64 Shore D color green	
19	19 000	17	34	21	42
24	14 000	60	120	75	150
28	11 500	160	320	200	400
38	9 500	325	650	405	810
48	8 000	530	1060	660	1350
65	4 000	950	1900	1100	2150

- > Maximum transmittable torque in accordance with the bore diameter of the clamping hub
At speeds over 10 000 rpm a precision balancing is necessary.

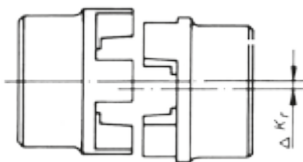

Radial misalignment

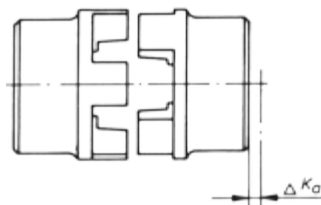

Axial misalignment

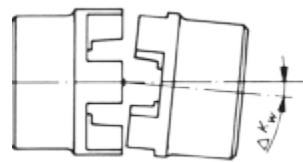

Angular misalignment

Size	Star	Radial misalignment [mm]	Axial misalignment [mm]	Angular misalignment [degree]
19	98 Shore A	0.1	±2	1
	64 Shore D	0.08		0.8
24	98 Shore A	0.12	±2	1
	64 Shore D	0.1		0.8
28	98 Shore A	0.15	±2	1
	64 Shore D	0.12		0.8
38	98 Shore A	0.18	±2	1
	64 Shore D	0.14		0.8
48	98 Shore A	0.2	±2	1
	64 Shore D	0.18		0.8
65	98 Shore A	0.25	±2	1
	64 Shore D	0.2		0.8



TYPE HPN

WITH KEYWAY MOUNTING

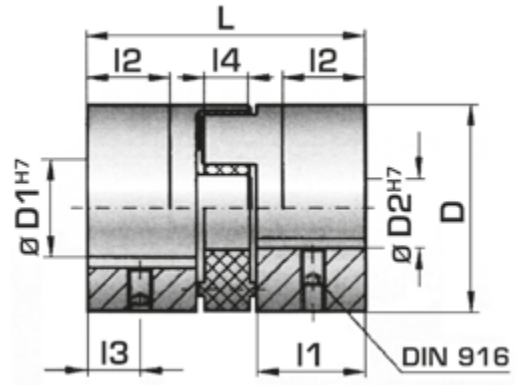
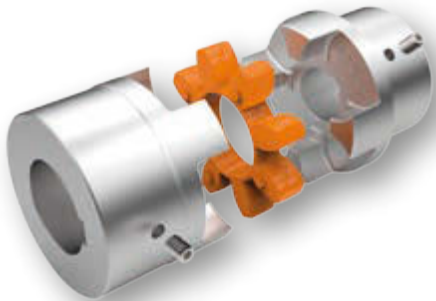

Size	D mm	D1/2 mm	l1 mm	l2 mm	l3 mm	l4 mm	L mm	Weight kg
19	42	8 - 25	25	19	8.5	12	66	0.15
24	56	12 - 32	30	22	10	14	78	0.35
28	66.5	19 - 38	35	26	12	15	90	0.6
38	82	20 - 45	45	32	15	18	114	1.1
48	102	28 - 60	50	37	17.5	20	126	1.7
65	136.5	32 - 80	65	43	23	25	162	11

- › Drill holes H7 with keyway in accordance with DIN 6885/1 . Set screws on the keyway. Optionally pilot bore. Weights valid for medium bore diameters

TYPE HPK

WITH CLAMPING HUB

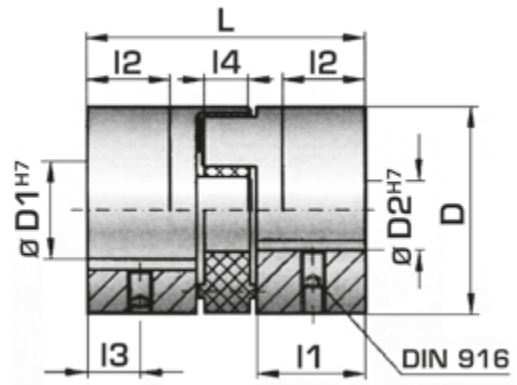
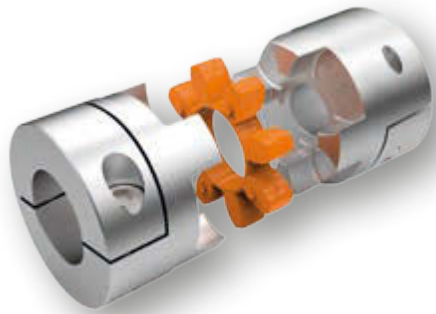

Size	D mm	D1/2 mm	l1 mm	l2 mm	l3 mm	L mm	Weight kg
19	42	8 - 25	25	39	8.5	66	0.15
24	56	12 - 32	30	46	10	78	0.35
28	66.5	19 - 38	35	52.5	12	90	0.6
38	82	20 - 45	45	66	15	114	1.1
48	102	28 - 60	50	73	17.5	126	1.7
65	136.5	32 - 80	65	93.5	23	162	11

MAXIMUM TRANSMITTABLE TORQUE IN ACCORDANCE WITH THE BORE DIAMETER OF THE CLAMPING HUB (NM)

Size	ø 8	ø 16	ø 19	ø 25	ø 30	ø 32	ø 35	ø 45	ø 50	ø 55	ø 60	ø 65	ø 70	ø 75	ø 80
19	20	35	45	60											
24		50	80	100	110	120									
28			120	160	180	200	220								
38			200	230	300	350	380	420							
48					420	480	510	600	660	750	850				
65							700	750	800	835	865	900	925	950	1000

> Higher torques with additional keyway possible!

ALLOCATION TO IEC MOTOR

Size of the three-phase motor	Power P of the IEC motors and allocated Habix® couplings								Shaft ends	
	3000 rpm		1500 rpm		1000 rpm		750 rpm		Form E DIN 748 part 3 d x l at speed approx.	
	P kw	Habix® size	P kw	Habix® size	P kw	Habix® size	P kw	Habix® size	3000 rpm	1500 rpm and less
56	0.09	19	0.06	19	0.037	19	-	-	9 x 20	
	0.12	19	0.09	19	0.045	19	-	-		
63	0.18	19	0.12	19	0.06	19	-	-	11 x 23	
	0.25	19	0.18	19	0.09	19	-	-		
71	0.37	19	0.25	19	0.18	19	0.09	19	14 x 30	
	0.55	19	0.37	19	0.25	19	0.12	19		
80	0.75	19	0.55	19	0.37	19	0.18	19	19 x 40	
	1.1	19	0.75	19	0.55	19	0.25	19		
90 S	1.5	24	1.1	24	0.75	24	0.37	24	24 x 50	
90 L	2.2	24	1.5	24	1.1	24	0.55	24	24 x 50	
100 L	3	28	2.2	28	1.5	28	0.75	28	28 x 60	
	-	-	3	28	-	-	1.1	28		
112 M	4	28	4	28	2.2	28	1.5	28	28 x 60	
132 S	5.5	38	5.5	38	3	38	2.2	38	38 x 80	
	7.5	38	-	-	-	-	-	-		
132 M	-	-	7.5	38	4	38	3	38	38 x 80	
	-	-	-	-	5.5	38	-	-		
160 M	11	42	11	42	7.5	42	4	42	42 x 110	
	15	42	-	-	-	-	5.5	42		
160 L	18.5	42	15	42	11	42	7.5	42	42 x 110	
180 M	22	48	18.5	48	-	-	-	-	48 x 110	
180 L	-	-	22	48	15	48	11	48	48 x 110	
200 L	30	55	30	55	18.5	55	15	55	55 x 110	
	37	55	-	-	22	55	-	-		
225 S	-	-	37	65	-	-	18.5	65	55 x 110	60 x 140
225 M	45	55	45	65	30	65	22	65	55 x 110	60 x 140
250 M	55	65	55	65	37	65	30	65	60 x 140	65 x 140
280 S	75	65	75	75	45	75	37	75	65 x 140	75 x 140
280 M	90	65	90	75	55	75	45	75	65 x 140	75 x 140
315 S	110	65	110	90	75	90	55	90	65 x 140	80 x 170
315 M	132	65	132	90	90	90	75	90	65 x 140	80 x 170
315 L	160	65	160	90	110	90	90	90	65 x 140	80 x 170
	200	75	200	90	132	90	110	90	-	-
355 L	250	75	250	90	160	90	132	90	-	-
	315	90	315	90	200	90	160	-	75 x 140	95 x 170
400 L	-	-	-	-	250	-	200	-	-	-
	355	90	355	-	315	-	250	-	80 x 170	100 x 210
	400	90	400	-	-	-	-	-	-	-

- > As proposed in the table (page 12) for surface cooled three-phase motors with cage rotor acc. to DIN 42673, page 1 (data for motor 56, 63, 71, 80, 315 L, 355 L, 400 L, see catalogue Siemens).

This allocation is a preliminary selection for normal conditions of operation.
 For conditions of operation under shock and changing loads the selection must be made according to the following.

SELECTION

- > The torque of the machine T_{AN} is determined by:

$$T_{AN} \text{ [Nm]} = 9550 \times \frac{P_{\text{Motor}} \text{ [kW]}}{n \text{ [rpm]}}$$

- > This torque T_{AN} multiplied by a safety factor S depending on the application and the temperature factor S_T (see table page 14) gives the required nominal coupling torque T_{KN} .

Result: $T_{KN} \geq S \times S_T \times T_{AN}$

DESIGN EXAMPLE FOR IEC STANDARD MOTORS

Dates of the plant

Driving machine:	
three-phase motor	225 M
Power of the motor:	P = 45 kW
Rotation at speed:	n = 1485 rpm
Driven machine:	mixer
Ambient temperature:	+50 °C

Layout of the coupling

$$T_{AN} \text{ [Nm]} = 9550 \times \frac{45 \text{ kW}}{1485 \text{ rpm}} = 290 \text{ Nm}$$

$$T_{KN} = 1.25 \times 1.5 \times 290 \text{ Nm} = 544 \text{ Nm}$$

- > Selection:
 Habix® size 65 flexible element 92° Shore A

$$T_{KN} = 625 \text{ Nm}$$

- > In case that bigger shock or changing loads occur we recommend a revision according to DIN 740.

An adequate calculation program is available.
 For such a revision the following information is required:

1. Kind of the driving machine
2. Kind of the driven machine
3. Power of driving and driven machines
4. Rotational speed of operation
5. Shock loads
6. Exciting loads
7. Moments of inertia of load- and driving sides
8. Starts per hour
9. Ambient temperature

SAFETY FACTOR S

Assignment of load characteristics according to type of working machine

S	DREDGERS	S	RUBBER MACHINERY	S	PUMPS
S	Bucket conveyor	M	Extruders	G	Piston pumps
M	Landing gear (caterpillar)	S	Calenders	M	Centrifugal pumps (light liquids)
M	Landing gear (rail)	M	Kneading mills	S	Centrifugal pumps (viscous liquids)
M	Manoeuvring winches	S	Mixers	S	Plunger pumps
S	Pumps		Rolling mills	S	Press pumps
S	Impellers				
S	Cutter heads		WOOD WORKING MACHINES		STONE AND CLAY
M	Slewing gear	S	Barkers		WORKING MACHINES
		M	Planing machines	S	Crusher
M	GENERATORS, TRANSFORMERS	G	Wood working machines	S	Rotary ovens
M	Frequency transformers	S	Saw frames	S	Hammer mills
M	Generators			S	Ball mills
M	Welding generators			S	Tube mills
			CRANES	S	Beater mills
		G	Luffing gear block	S	Brick presses
		S	Travelling gear		
M	CHEMICAL INDUSTRY	G	Hoist gear		TEXTILE MACHINES
M	Cooling drums	M	Slewing gear	M	Batchers
G	Mixers	M	Derricking jib gear	M	Printing and dyeing machines
M	Agitators (liquid material)			M	Tanning vats
M	Agitators (semi-liquid material)		PLASTIC INDUSTRY MACHINES	M	Willows
M	Drying drums	M	Extruders	M	Looms
G	Centrifuges (light)	M	Calenders		
M	Centrifuges (heavy)	M	Mixers		COMPRESSORS
		M	Crushers	S	Piston compressors
M	OIL INDUSTRY			M	Turbo compressors
S	Pipeline pumps		METAL WORKING MACHINES		
	Rotary drilling equipment	M	Plate bending machines		METAL ROLLING MILLS
		S	Plate straightening machines	S	Plate shears
M	CONVEYORS	S	Hammers	M	Manipulator for turning sheets
S	Pit-head winches	S	Metal planning machines	S	Ingot pushers
M	Winding engines	M	Presses	S	Ingot and slabbing-mill train
M	Jointed-band conveyors	S	Shears	S	Ingot handling machinery
G	Belt conveyors (bulk material)	S	Forging presses	M	Wire drawing benches
M	Belt conveyors (piece goods)	G	Punch presses	S	Descaling machines
M	Band pocket conveyors	M	Countershafts, line shafts	S	Thin plate mills
M	Chain conveyors	M	Machine tools (main drives)	S	Heavy and medium plate mills
M	Circular conveyors	G	Machine tools (auxiliary drives)	M	Winding machines (strip and wire)
M	Load elevators			S	Cold rolling mills
G	Bucket conveyors for flour		FOOD INDUSTRY MACHINERY	M	Chain tractor
M	Passenger lifts	G	Bottling and container filling machines	S	Billet shears
M	Plate conveyors	M	Kneading machines	M	Cooling beds
M	Screw conveyors	G	Mash tubs	M	Cross tractor
M	Ballast elevators	M	Packaging machines	M	Roller tables (light)
S	Inclined hoists	M	Cane crushers	S	Roller tables (heavy)
M	Steel belt conveyors	S	Cane cutters	M	Roller straighteners
M	Drag chain conveyors	S	Cane mills	S	Tube welding machines
		M	Sugar beet cutters	M	Trimming shears
		M	Sugar beet washing machines	S	Cropping shears
M	BLOWERS, VENTILATORS			S	Continuous casting plant
G	Rotary piston blowers		PAPER MACHINES	M	Rollers adjustment drive
M	Blowers (axial/radial)	S	Couches	S	Manipulators
M	Cooling tower fans	S	Glazing cylinders		
M	Induced draught fans	M	Pulper		LAUNDRIES
G	Turbo blowers	S	Pulp grinders	M	Tumblers
		M	Calenders	M	Washing machines
		S	Wet presses		
S	BUILDING MACHINERY	S	Willows		WATER TREATMENT
G	Hoists	S	Suction presses	M	Aerators
S	Concrete mixers	S	Suction rolls	M	Screw pumps
S	Road construction machinery	S	Drying cylinders		

Operating factor S				Habix®		Habix®plus		
Driving machines	Load characteristics of the working machine			Temperature factor S _T		Temperature factor S _T		
	G	M	S	θ [°C]	S _T	θ [°C]	Shore 98 A	Shore 64 D
Electric motors, turbines, hydraulic motors	1	1.25	1.75	-20° to +30°	1.0	-30° to -10°	1.5	1.7
Piston machines 4-6 cylinders, degree of nonuniformity 1:100 - 1:200	1.25	1.5	2	+30° to +40°	1.2	-10° to +30°	1.0	1.0
Piston machines 1-3 cylinders, degree of nonuniformity up to 1:100	1.5	2	2.5	+40° to +60°	1.5	+30° to +40°	1.2	1.1
				+60° to +80°	1.8	+40° to +60°	1.4	1.3
						+60° to +80°	1.7	1.5
						+80° to +100°	2.0	1.8
						+100° to +120°	-	2.4

TECNAMIC

Dynamic Drive Technology

FLEXIBLE COUPLINGS

HADEFLEX® X/TX/F



HADEFLEX®

HADEFLEX®

The flexible HadeFlex® couplings are claw couplings with a flexible element to provide a torsionally flexible connection for shafts. The flexible elements excel in their wear resistance, their oil, ozone and ageing resistance and their temperature resistance from -20 °C to +80 °C. Thanks to their flexibility, impacts, rotary vibrations and noises are effectively absorbed. The flexible elements are dimensioned such that radial, axial and angular movements between the two halves of the coupling are cancelled out. The flexible HadeFlex® couplings are of the plug-in type for installation and do not involve any particularly rigorous requirements with respect to alignment accuracy. HadeFlex® couplings can be used in the whole of machine construction wherever a reliable shaft connection is needed between motor and working machine.

TYPE X

The HadeFlex® version X coupling is fail-safe up to the fracture moment of the cast iron transmission cam and this provides maximum operational safety. The coupling star can be supplied with hardness 92 Shore A and 98 Shore A. With the fixed position of the coupling star its deformability in axial direction is free, and so no damaging axial forces can act on the machine bearing even with alternating torque.

TYPE TX - WITH TAPER BUSH

The HadeFlex® version TX coupling combines the outstanding features of the flexible couplings with the advantages of the taper bush system: fast and easy installation for a torsionally flexible connection between shafts and elimination of shaft balancing errors. The TX type with taper bush has the advantage that even with greater shaft tolerances there is a backlash-free and at the same time axial fixing of the shaft. In addition the close sliding fit makes axial alignment of the coupling easier. The coupling star can be replaced by a simple

axial displacement of the coupling halves without having to disassemble the machines connected.

TYPE F

The HadeFlex® version F coupling is manufactured in two-piece and three-piece variants. With the two-piece coupling (FW series) it is possible to install packages after axial displacement of the drive engines or working machines. With the three-piece coupling (FNW series) it is possible to install packages without axial displacement of the drive engine or working machine.



TYPE TX 03

FOR TAPER BUSH

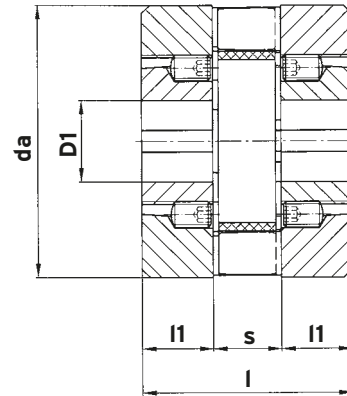

HADEFLEX®

Size	Bush no.	D1		da	l	l1	s	Max. rotation speed rpm	Weight ⁴⁾ kg	Moments of inertia ⁴⁾ kgm ²	Max. shaft misalignment ³⁾		
		min. mm	max. mm								radial ← K _r mm	axial ← K _a mm	angular ← K _w degree
28	1108	10	28	71	66	23	20	9900	1.26	0.0004	0.3	0.5	0.7
42	1610	14	42	100	77	26	25	7000	2.92	0.0020	0.4	1.0	0.7
60	2517	16	60	147	120	45	30	4700	10.5	0.0158	0.5	1.0	0.7
75	3020	25	75	181	142	51	40	3800	18.9	0.0437	0.6	1.0	0.7
90	3535	35	90	217	224	89	46	3200	44.0	0.144	0.7	1.0	0.7
110	4545	55	110	271	284	115	54	2500	88.1	0.450	0.9	1.0	0.7

Size	Torque 92° Shore A black/98° Shore A red ¹⁾				Torsion spring rigidity C dyn in Nm/rad							
	92° nominal T _{KN} Nm	98° nominal T _{KN} Nm	max. T _{KN max} Nm	changing T _{KN 2)} Nm	92° Shore 1/4 T _{KN}	92° Shore 1/2 T _{KN}	92° Shore 3/4 T _{KN}	92° Shore 1/1 T _{KN}	98° Shore 1/4 T _{KN}	98° Shore 1/2 T _{KN}	98° Shore 3/4 T _{KN}	98° Shore 1/1 T _{KN}
	28	63	80	190	25	2450	2950	3900	5350	3100	4450	7350
42	220	280	660	80	7900	9850	13550	18750	10450	15550	26400	41600
60	630	800	1900	230	22600	28400	38300	50000	30350	44450	73300	108300
75	1250	1500	3750	450	44950	62850	81500	99350	58050	80600	123750	178500
90	2500	3000	7500	825	90100	130000	176500	223500	117900	173800	253300	355900
110	4000	5000	12000	1500	175700	223400	279200	337400	190600	254100	348500	477500

- 1) Torques for shaft fit with keyway
- 2) Maximum alternating torque up to f = 10 Hz
- 3) The values mentioned are valid for n = 600 rpm and may occur only separately.
At multiple misalignments or higher speeds the values must be reduced (see page 10).
- 4) The information concerning weights and moments of inertia apply for max. drill holes per coupling;
coupling half materials: EN-GJL-250 (GG-25) in accordance with DIN EN 1561.

TAPER BUSHES WITH KEYWAY ACC. TO DIN 6885/1

TOLERANCE JS9

Taper bush no.	Bore \varnothing of available taper bushes mm											
	10	11	12	14	16	18	19	20	22	24	25	28*
1108	10	11	12	14	16	18	19	20	22	24	25	28*
1610	14	16	18	19	20	22	24	25	28	30	32	35
	38	40	42*									
2517	16	18	19	20	22	24	25	28	30	32	35	38
	40	42	45	48	50	55	60					
3020	25	28	30	32	35	38	40	42	45	48	50	55
	60	65	70	75								
3535	35	38	40	42	45	48	50	55	60	65	70	75
	80	85	90									
4545	55	60	65	70	75	80	85	90	95	100	105	110

* These bore holes are with flat keyway in accordance with DIN 6885/3.

TECHNICAL DATA XW1

Size	Torque 92° Shore A nature / 98° Shore A blue ¹⁾				Torsion spring rigidity C dyn in Nm / rad							
	92° nominal T_{KN}	98° nominal T_{KN}	max. $T_{KN \max}$	changing $T_{KW}^{2)}$	92° Shore	92° Shore	92° Shore	92° Shore	98° Shore	98° Shore	98° Shore	98° Shore
	Nm	Nm	Nm	Nm	1/4 T_{KN}	1/2 T_{KN}	3/4 T_{KN}	1/1 T_{KN}	1/4 T_{KN}	1/2 T_{KN}	3/4 T_{KN}	1/1 T_{KN}
24	40	52	120	15	2150	3300	4200	4800	5550	8650	16600	29400
28	63	80	190	25	2850	4300	6050	8100	7000	10750	19650	33300
32	100	120	300	35	3700	6000	8500	11100	8300	12850	23800	40500
38	160	200	480	60	5800	8800	12600	16800	11600	17600	31850	55800
42	220	280	660	80	8100	11600	17400	25200	14250	22500	42000	75400
48	320	400	960	120	10400	16800	24800	34700	16400	28700	49950	79200
55	450	600	1350	180	13250	23500	34000	44550	20650	39700	69600	109400
60	630	800	1900	230	17600	32600	46800	55900	24900	50800	90250	140700
65	900	1000	2700	300	29200	46800	66400	85600	35500	72500	120400	174800
75	1250	1500	3750	450	42250	69200	95650	124200	46800	97400	165600	238600
85	1800	2250	5400	675	55900	94450	135450	177000	61100	120400	222300	350300
100	3000	3800	9000	1125	110600	166100	220400	268900	93600	192500	330000	482600
110	4000	5000	12000	1500	120100	220100	309500	386900	130500	251000	439500	641000
125	5600	7000	16800	2200	220500	331700	446000	548600	229700	358000	616500	821000
140	8000	10000	24000	3000	292200	430100	602400	723500	255200	465100	785200	1192600
160	12500	15000	37500	4500	319000	547000	847500	1273000	364000	640000	1018000	1500000

Size	Max. shaft misalignment ³⁾		
	radial $\leftarrow K_r$ mm	axial $\leftarrow K_a$ mm	angular $\leftarrow K_w$ degree
24	0.3	1.2	0.7
28	0.3	1.2	0.7
32	0.3	1.2	0.7
38	0.4	1.5	0.7
42	0.4	1.5	0.7
48	0.4	1.5	0.7
55	0.5	1.8	0.7
60	0.5	1.8	0.7

Size	Max. shaft misalignment ³⁾		
	radial $\leftarrow K_r$ mm	axial $\leftarrow K_a$ mm	angular $\leftarrow K_w$ degree
65	0.5	1.8	0.7
75	0.6	2.1	0.7
85	0.7	2.1	0.7
100	0.8	2.4	0.7
110	0.9	2.4	0.7
125	1.0	3.0	0.7
140	1.1	3.0	0.7
160	1.2	3.0	0.7

1) Torques for shaft fit with keyway - 2) Maximum alternating torque up to $f = 10$ Hz - 3) The values mentioned are valid for $n = 600$ rpm and may occur only separately. At multiple misalignments or higher speeds the values must be reduced (see page 10).

TYPE XW 1

FOR KEYWAY MOUNTING

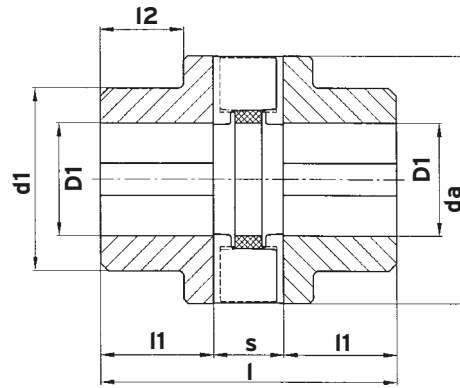

Size	D1 pre.	D1 (H7) ¹⁾		da	d1	l	l1	l2	s	Max. rotation speed rpm	Weight ²⁾ kg	Moments of inertia ²⁾ kgm ²
		min. mm	max. mm									
24*	-	-	24	55	55	66	24	-	18	12 500	0.55	0.0002
28*	-	-	28	62	62	76	28	-	20	11100	0.76	0.0004
32	9	11	32	70	52	86	32	22	22	9800	1.09	0.0006
38	14	16	38	84	60	100	38	27	24	8100	1.76	0.0014
42	14	16	42	92	68	110	42	31	26	7400	2.38	0.0024
48	17	19	48	105	76	124	48	36	28	6500	3.38	0.0042
55	17	19	55	120	88	140	55	43	30	5700	4.89	0.0080
60	22	24	60	130	96	152	60	47	32	5200	6.29	0.012
65	24	26	65	142	104	165	65	51	35	4800	8.15	0.018
75	30	32	75	165	120	190	75	59	40	4100	12.60	0.038
85	40	42	85	185	136	214	85	68	44	3700	17.90	0.068
100	58	60	100	220	160	250	100	80	50	3100	29.30	0.156
110	68	70	110	240	176	275	110	88	55	2800	38.50	0.246
125	68	70	125	275	200	310	125	100	60	2500	56.70	0.470
140	78	80	140	310	224	345	140	113	65	2200	79.00	0.824
160	88	90	160	360	255	395	160	130	75	1900	119.40	1.654

1) Drill holes H7 with keyway in accordance with DIN 6885/1; tolerance zone JS9 and set screws on the keyway

2) The information concerning weights and moments of inertia apply for max. drill holes per coupling;
coupling half materials: EN-GJL-250 (GG-25) in accordance with DIN EN 1561 or *aluminium.

ALLOCATION TO IEC MOTORS XW1

Size of the three-phase motor	Power P of the IEC motors and allocated Hadeflex® couplings X								Shaft ends	
	3000 rpm P Hadeflex® kw size		1500 rpm P Hadeflex® kw size		1000 rpm P Hadeflex® kw size		750 rpm P Hadeflex® kw size		Form E DIN 748 part 3 d + l at speed approx.	
									3000 rpm	1500 rpm and less
56	0.09	24	0.06	24	0.037	24	-	-	9 + 20	
	0.12	24	0.09	24	0.045	24	-	-		
63	0.18	24	0.12	24	0.06	24	-	-	11 + 23	
	0.25	24	0.18	24	0.09	24	-	-		
71	0.37	24	0.25	24	0.18	24	0.09	24	14 + 30	
	0.55	24	0.37	24	0.25	24	0.12	24		
80	0.75	24	0.55	24	0.37	24	0.18	24	19 + 40	
	1.1	24	0.75	24	0.55	24	0.25	24		
90 S	1.5	24	1.1	24	0.75	24	0.37	24	24 + 50	
90 L	2.2	24	1.5	24	1.1	24	0.55	24	24 + 50	
100 L	3	28	2.2	28	1.5	28	0.75	28	28 + 60	
	-	-	3	28	-	-	1.1	28		
112 M	4	28	4	28	2.2	28	1.5	28	28 + 60	
132 S	5.5	38	5.5	38	3	38	2.2	38	38 + 80	
	7.5	38	-	-	-	-	-	-		
132 M	-	-	7.5	38	4	38	3	38	38 + 80	
	-	-	-	-	5.5	38	-	-		
160 M	11	42	11	42	7.5	42	4	42	42 + 110	
	15	42	-	-	-	-	5.5	42		
160 L	18.5	42	15	42	11	42	7.5	42	42 + 110	
180 M	22	48	18.5	48	-	-	-	-	48 + 110	
180 L	-	-	22	48	15	48	11	48	48 + 110	
200 L	30	55	30	55	18.5	55	15	55	55 + 110	
	37	55	-	-	22	55	-	-		
225 S	-	-	37	60	-	-	18.5	60	55 + 110	60 + 140
225 M	45	55	45	60	30	60	22	60	55 + 110	60 + 140
250 M	55	60	55	65	37	65	30	65	60 + 140	65 + 140
280 S	75	65	75	75	45	75	37	75	65 + 140	75 + 140
280 M	90	65	90	75	55	75	45	75	65 + 140	75 + 140
315 S	110	65	110	85	75	85	55	85	65 + 140	80 + 170
315 M	132	65	132	85	90	85	75	85	65 + 140	80 + 170
315 L	160	75	160	85	110	85	90	100	65 + 140	80 + 170
	200	75	200	100	132	100	110	100		
355 L	250	85	250	100	160	100	132	110	75 + 140	95 + 170
	315	85	315	110	200	110	160	110		
	-	-	-	-	250	125	200	125		
400 L	355	100	355	125	315	125	250	140	80 + 170	100 + 210
	400	100	400	125	-	-	-	-		

As proposed in the table for surface cooled three-phase motors with cage rotor acc. to DIN 42673, page1 (data for motor 56, 63, 71, 80, 315 L, 355 L, 400 L, see catalogue Siemens). This allocation is a preliminary selection for normal conditions of operation.

For conditions of operation under shock and changing loads the selection must be made according to the layout.

TECHNICAL DATA FW-FNW



Size	Torque Perbunan rigidity 80° Shore A ¹⁾			Torsion spring rigidity C dyn in Nm / rad				Max. shaft misalignment ³⁾		
	nominal T_{KN} Nm	max. $T_{KN\ max}$ Nm	changing T_{KW} ²⁾ Nm	$1/4 T_{KN}$	$1/2 T_{KN}$	$3/4 T_{KN}$	$1/1 T_{KN}$	radial	axial	angular
								$\leftarrow K_r$, mm	$\leftarrow K_a$, mm	$\leftarrow K_w$, mm
1	12	18	3	900	1100	1250	1450	0.3	1	0.3
2	16	24	4	1150	1450	1750	2150	0.3	1	0.3
3	24	36	6	1600	2050	2550	3100	0.3	3	0.3
4	30	45	7	2050	2550	3150	3700	0.4	3	0.3
5	50	75	12	3550	4400	5350	6400	0.4	3	0.3
6	110	165	27	7700	9700	11800	13900	0.4	3	0.3
7	150	225	37	10550	13250	16100	19100	0.5	3	0.3
8	310	465	77	21750	27150	32900	39350	0.5	4	0.3
9	480	720	120	26400	34950	43800	52550	0.5	4	0.3
9 a	860	1290	215	39100	54400	67500	82650	0.5	4	0.3
10	1220	1830	305	44400	64450	85300	108350	0.6	5	0.3
10 a	1760	2640	440	76100	91600	116200	150650	0.6	5	0.3
11	2480	3720	620	76900	92500	131950	188500	0.7	5	0.3
12	3830	5745	957	114550	168100	245150	338900	0.8	6	0.3
13	5730	8595	1432	171250	242050	346850	483950	0.9	6	0.3
14	9550	14325	2387	275600	394150	567500	799450	1.0	6	0.3
15	12880	19320	3220	370750	529850	766250	1090700	1.1	6	0.3
16	20000	30000	5000	566800	809650	1178450	1671850	1.2	6	0.3

1) Torques for shaft fit with keyway

2) Maximum alternating torque up to $f = 10$ Hz

3) The values mentioned are valid for $n = 600$ rpm and may occur only separately.

At multiple misalignments or higher speeds the values must be reduced.

TYPE FW

FOR KEYWAY MOUNTING

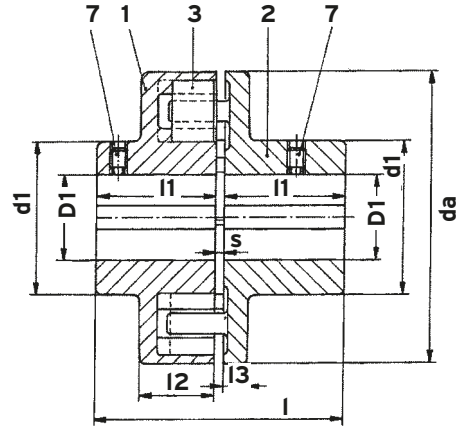
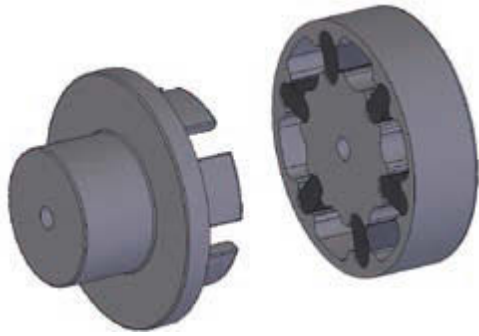

Size	D1 pre.	D1 (H7) ¹⁾		da	d1	l	l1	l2	l3	s	Max. rotation speed rpm	Weight ²⁾ kg	Moments of inertia ²⁾ kgm ²
		min. mm	max. mm										
1	-	-	15	75	35	78	38	30	8	2	9700	1.08	0.00065
2	-	-	18	80	45	82	40	30	10	2	9000	1.44	0.00098
3	-	-	28	90	50	88	43	31	10	2	7300	1.78	0.00164
4	-	-	30	100	60	92	45	32	10	2	6600	2.45	0.0026
5	11	13	38	120	65	102	50	35	12	2	5500	3.56	0.0058
6	16	18	42	150	70	122	60	42	12	2	4200	6.07	0.0147
7	19	21	50	170	90	143	70	44	14	3	3900	9.35	0.029
8	24	26	65	210	110	163	80	53	16	3	3100	16.30	0.078
9	32	34	80	250	140	223	110	55	18	3	2700	30.00	0.191
9 a	38	40	90	280	160	223	110	66	21	3	2400	40.10	0.331
10	43	45	105	300	180	263	130	68	22	3	2100	52.30	0.488
10 a	53	55	110	340	200	303	150	70	24	3	1950	77.80	0.892
11	58	60	125	370	215	323	160	72	25	3	1800	93.90	1.286
12	68	70	140	440	245	364	180	96	28	4	1600	149.40	2.94
13	88	90	160	500	280	404	200	100	33	4	1350	216.00	5.43

1) Drill holes H7 with keyway in accordance with DIN 6885/1; tolerance zone JS9 and set screws on the keyway

2) The information concerning weights and moments of inertia apply for max. drill holes per coupling;
coupling half materials: EN-GJL-250 (GG-25) in accordance with DIN EN 1561.

TYPE FNW

FOR KEYWAY MOUNTING

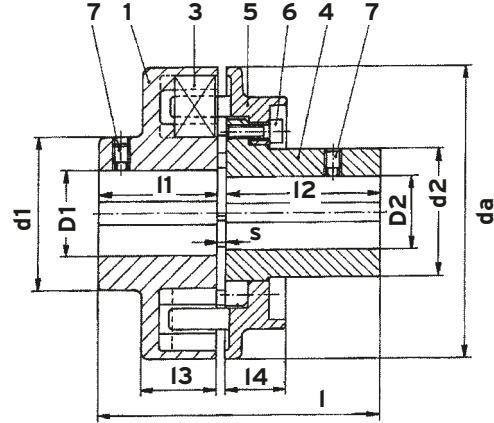

HADEFLEX®

Size	D1 (H7) ¹⁾		D2 (H7) ¹⁾		da	d1	d2	l	l1	l2	l3	l4	s	Max. rotation speed	Weight ²⁾	Moments of inertia ²⁾
	min. mm	max. mm	min. mm	max. mm												
6	18	42	18	35	150	75	65	142	60	80	42	28	2	4200	6.57	0.0149
7	21	50	21	45	170	90	72	163	70	90	44	35	3	3900	9.66	0.029
8	26	65	26	55	210	110	97	183	80	100	53	35	3	3100	17.10	0.078
9	34	80	34	75	250	140	126	223	110	110	55	42	3	2700	29.60	0.186
9 a	40	90	40	80	280	160	130	243	110	130	66	49	3	2400	39.50	0.316
10	45	105	45	90	300	180	150	263	130	130	68	49	3	2100	50.00	0.456
10 a	55	110	55	100	340	200	180	303	150	150	70	49	3	1950	75.30	0.843
11	60	125	60	120	370	215	205	323	160	160	72	58	3	1800	95.40	1.294
12	70	140	70	130	440	245	230	364	180	180	96	64	4	1600	151.40	2.93
13	90	160	90	160	500	280	280	404	200	200	100	70	4	1350	222.60	5.54
14	100	180	100	180	560	310	310	444	220	220	102	76	4	1100	289.90	9.26
15	130	200	130	200	620	340	340	524	260	260	105	86	4	1100	402.60	15.23
16	-	220	-	220	710	375	375	566	280	280	130	93	6	900	560.50	27.9

- 1) Drill holes H7 with keyway in accordance with DIN 6885/1; tolerance zone JS9 and set screws on the keyway
- 2) The information concerning weights and moments of inertia apply for max. drill holes per coupling;
coupling half materials: EN-GJL-250 (GG-25) in accordance with DIN EN 1561.

ALLOWABLE MISALIGNMENTS



Radial misalignment

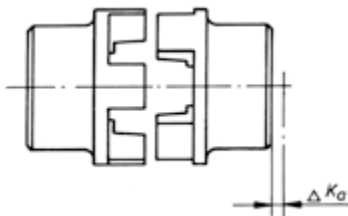

Axial misalignment



Angular misalignment

Reduction of the allowable values of misalignment when the combination of misalignments occur or at other rotational speeds:

$$\frac{\leftarrow W_r}{\leftarrow K_r} + \frac{\leftarrow W_a}{\leftarrow K_a} + \frac{\leftarrow W_w}{\leftarrow K_w} \leq 1 \quad = \text{applies to speeds of 600 rpm}$$

$$\leq 0.8 \quad 601-1000 \text{ rpm}$$

$$\leq 0.65 \quad 1001-1500 \text{ rpm}$$

$$\leq 0.50 \quad 1501-3000 \text{ rpm}$$

$\leftarrow K_{r/a/w}$ = allowable radial, axial or angular misalignment of the shafts resp. of the coupling halves

$\leftarrow W_{r/a/w}$ = measured radial, axial or angular misalignment of the shafts resp. of the coupling halves

SELECTION

The torque of the machine T_{AN} is determined by $T_{AN} [\text{Nm}] = 9550 \times \frac{P_{\text{Motor}} [\text{kW}]}{n [\text{rpm}]}$

This torque T_{AN} multiplied by a safety factor S depending on the application and the temperature factor S_T (see table page 11) gives the required nominal coupling torque T_{KN} .

Result: $T_{KN} \geq S \times S_T \times T_{AN}$

➤ In case that bigger shock or changing loads occur we recommend a revision according to DIN 740. An adequate calculation program is available. For such a revision the following information is required:

1. Kind of the driving machine
2. Kind of the driven machine
3. Power of driving and driven machines
4. Rotational speed of operation
5. Shock loads
6. Exciting loads
7. Moments of inertia of load- and driving sides
8. Starts per hour
9. Ambient temperature

DATES OF THE PLANT

Driving machine

Three-phase motor: Size 315L
 Power of the motor: P = 110 kW
 Rotation at speed: n = 1000 rpm
 Driven machine: mixer
 Ambient temperature: +35°C

Selection

XW1 Size 100 flexible spider 92° Shore A
 $T_{KN} = 3000 \text{ Nm}$
 TX 03 Size 90 flexible spider 92° Shore A
 $T_{KN} = 2500 \text{ Nm}$
 FW Size 11 $T_{KN} = 2480 \text{ Nm}$
 FNW Size 11 $T_{KN} = 2480 \text{ Nm}$

Layout of the coupling

$$T_{AN} = 9550 \div \frac{110 \text{ kW}}{1000 \text{ rpm}} = 1051 \text{ Nm}$$

$$T_{KN} = 1.75 \div 1.2 \div 1051 \text{ Nm} = 2207 \text{ Nm}$$

SAFETY FACTOR S

Assignment of load characteristics according to type of working machine			
S	DREDGERS	S	RUBBER MACHINERY
S	Bucket conveyor	M	Extruders
M	Landing gear (caterpillar)	S	Calenders
M	Landing gear (rail)	M	Kneading mills
M	Manoeuvring winches	S	Mixers
S	Pumps	S	Rolling mills
S	Impellers		
S	Cutter heads		WOOD WORKING MACHINES
M	Slewing gear	S	Barkers
		M	Planing machines
M	GENERATORS, TRANSFORMERS	G	Wood working machines
M	Frequency transformers	S	Saw frames
M	Generators		
M	Welding generators		CRANES
		G	Luffing gear block
M	CHEMICAL INDUSTRY	S	Travelling gear
M	Cooling drums	G	Hoist gear
G	Mixers	M	Slewing gear
M	Agitators (liquid material)	M	Derricking jib gear
M	Agitators (semi-liquid material)		
M	Drying drums		PLASTIC INDUSTRY MACHINES
G	Centrifuges (light)	M	Extruders
M	Centrifuges (heavy)	M	Calenders
		M	Mixers
		M	Crushers
M	OIL INDUSTRY		
S	Pipeline pumps		METAL WORKING MACHINES
	Rotary drilling equipment	M	Plate bending machines
		S	Plate straightening machines
M	CONVEYORS	S	Hammers
S	Pit-head winches	S	Metal planning machines
M	Winding engines	S	Presses
M	Jointed-band conveyors	M	Shears
G	Belt conveyors (bulk material)	S	Forging presses
M	Belt conveyors (piece goods)	S	Punch presses
M	Band pocket conveyors	G	Countershafts, line shafts
M	Chain conveyors	M	Machine tools (main drives)
M	Circular conveyors	G	Machine tools (auxiliary drives)
M	Load elevators		
G	Bucket conveyors for flour		FOOD INDUSTRY MACHINERY
M	Passenger lifts	G	Bottling and container filling machines
M	Plate conveyors	M	Kneading machines
M	Screw conveyors	M	Mash tubs
M	Ballast elevators	G	Packaging machines
S	Inclined hoists	M	Cane crushers
M	Steel belt conveyors	M	Cane cutters
M	Drag chain conveyors	S	Cane mills
		M	Sugar beet cutters
		M	Sugar beet washing machines
M	BLOWERS, VENTILATORS		
G	Rotary piston blowers		PAPER MACHINES
M	Blowers (axial/radial)	S	Couches
M	Cooling tower fans	S	Glazing cylinders
M	Induced draught fans	M	Pulper
G	Turbo blowers	S	Pulp grinders
		M	Calenders
S	BUILDING MACHINERY	S	Wet presses
G	Hoists	S	Willows
S	Concrete mixers	S	Suction presses
	Road construction machinery	S	Suction rolls
		S	Drying cylinders
			PUMPS
		S	Piston pumps
		G	Centrifugal pumps (light liquids)
		M	Centrifugal pumps (viscous liquids)
		S	Plunger pumps
		S	Press pumps
			STONE AND CLAY WORKING MACHINES
		S	Crusher
		S	Rotary ovens
		S	Hammer mills
		S	Ball mills
		S	Tube mills
		S	Beater mills
		S	Brick presses
			TEXTILE MACHINES
		M	Batchers
		M	Printing and dyeing machines
		M	Tanning vats
		M	Willows
		M	Looms
			COMPRESSORS
		S	Piston compressors
		M	Turbo compressors
			METAL ROLLING MILLS
		S	Plate shears
		M	Manipulator for turning sheets
		S	Ingot pushers
		S	Ingot and slabbing-mill train
		S	Ingot handling machinery
		M	Wire drawing benches
		S	Descaling machines
		S	Thin plate mills
		S	Heavy and medium plate mills
		M	Winding machines (strip and wire)
		S	Cold rolling mills
		M	Chain tractor
		S	Billet shears
		M	Cooling beds
		M	Cross tractor
		M	Roller tables (light)
		S	Roller tables (heavy)
		M	Roller straighteners
		S	Tube welding machines
		M	Trimming shears
		S	Cropping shears
		S	Continuous casting plant
		M	Rollers adjustment drive
		S	Manipulators
			LAUNDRIES
		M	Tumblers
		M	Washing machines
			WATER TREATMENT
		M	Aerators
		M	Screw pumps

Operating factor S			
Driving machines	Load characteristics of the working machine		
	G	M	S
Electric motors, turbines, hydraulic motors	1	1.25	1.75
Piston machines 4-6 cylinders, degree of nonuniformity 1:100 - 1:200	1.25	1.5	2
Piston machines 1-3 cylinders, degree of nonuniformity up to 1:100	1.5	2	2.5

Temperature factor S _T	
θ [°C]	S _T
+20 < θ < +30	1.0
+30 < θ < +40	1.2
+40 < θ < +60	1.5
+60 < θ < +80	1.8

FLEXIBLE COUPLINGS

HRC

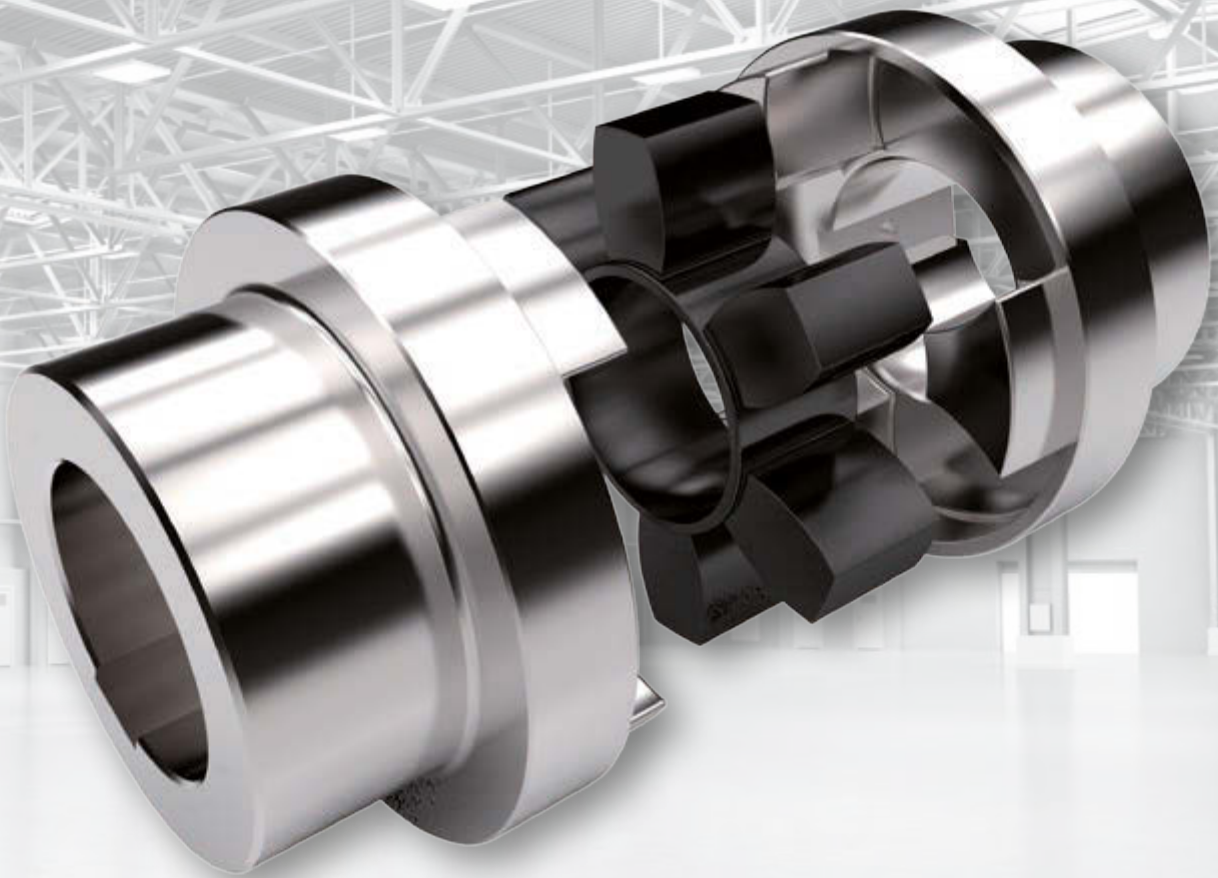

HRC

The flexible HRC coupling is a break-through safe claw coupling with a flexible element to provide a torsionally flexible connection of shafts. The flexible element, the coupling star, excels in its wear resistance, its oil, ozone and ageing resistance and its temperature resistance from -20°C to $+80^{\circ}\text{C}$. Thanks to the coupling's flexibility, impacts, rotary vibrations and noises are effectively absorbed. The coupling star is dimensioned such that radial and axial movements between the two halves of the coupling are cancelled out. With the fixed position of the coupling star its deformability in axial direction is free, and so no damaging axial forces can act on the machine bearing even with alternating torque. HRC couplings are fail-safe up to the fracture moment of the cast iron transmission cam and this provides maximum operational safety. The coupling is of the plug-in type for installation and does not involve any particularly rigorous requirements with respect to alignment accuracy. The HRC coupling can be used in the whole of machine construction wherever a reliable shaft connection is needed between motor and working machine.



TYPE

- Standard coupling
- Taper bush type
- Combined type standard/taper
- Components can be combined as needed

WITH TAPER BUSH

The HRC coupling combines the outstanding features of the flexible couplings with the advantages of the taper bush system: fast and easy installation for a torsionally flexible connection between shafts and elimination of shaft alignment errors. HRC couplings with taper bush have the advantage that even

with greater shaft tolerances there is a backlash-free and at the same time axial fixing of the shaft. In addition the close sliding fit makes axial alignment of the coupling easier. The coupling star can be replaced by a simple axial displacement of the coupling halves without having to disassemble the machines connected.

TECHNICAL DATA

Size	Max. rotation rpm	Torque ¹⁾ Nm		Torsion spring rigidity Nm/°	Moments of inertia ²⁾ kgm ²	Weight ²⁾	Max. shaft misalignment ³⁾		
		nominal T _{KN}	max. T _{Kmax}				radial ΔK _r mm	axial ΔK _a mm	angular ΔK _w degree
70	8100	31	72	-	0.00085	1.00	0.3	+0.2	1
90	6500	80	180	-	0.00115	1.17	0.3	+0.5	1
110	5200	160	360	65	0.00400	5.00	0.3	+0.6	1
130	4100	315	720	130	0.00780	5.46	0.4	+0.8	1
150	3600	600	1500	175	0.01810	7.11	0.4	+0.9	1
180	3000	950	2350	229	0.04340	16.6	0.4	+1.1	1
230	2600	2000	5000	587	0.12068	26.0	0.5	+1.3	1
280	2200	3150	7200	1025	0.44653	50.0	0.5	+1.7	1

- 1) Torques for shaft fit with keyway
- 2) The information concerning weights and moments of inertia apply for medium holes per coupling; coupling half materials: EN-GJL-250 (GG-25) in accordance with DIN EN 1561.
- 3) The values mentioned are valid for n = 600 rpm and may occur only separately. At multiple misalignments or higher speeds the values must be reduced.

HRC

ALLOWABLE MISALIGNMENTS

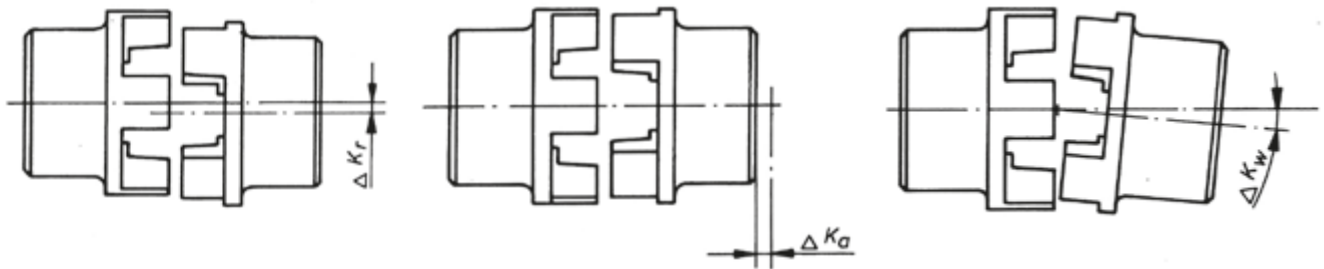

Radial misalignment

Axial misalignment

Angular misalignment

> Reduction of the allowable values of misalignment when the combination of misalignments occur or at other rotational speeds:

$$\frac{\Delta W_r}{\Delta K_r} + \frac{\Delta W_a}{\Delta K_a} + \frac{\Delta W_w}{\Delta K_w} \leq 1$$

<1 = applies to speeds of 600 rpm
 ≤ 0.8 601 - 1000 rpm
 ≤ 0.65 1001 - 1500 rpm
 ≤ 0.50 1501 - 3000 rpm

ΔK_{r/a/w} = allowable radial, axial or angular misalignment of the shafts resp. of the coupling halves

ΔW_{r/a/w} = measured radial, axial or angular misalignment of the shafts resp. of the coupling halves

HRC FLANGE B, F, H

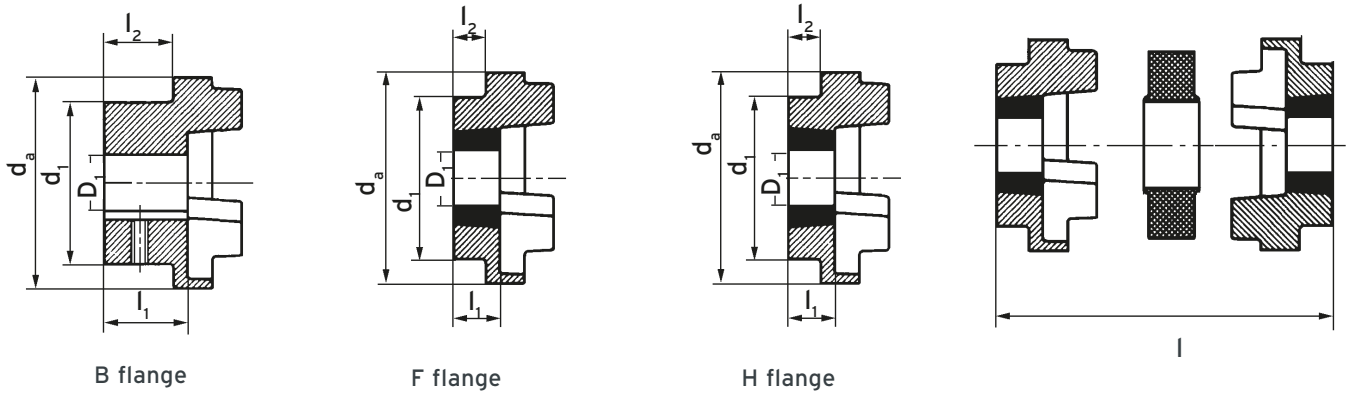
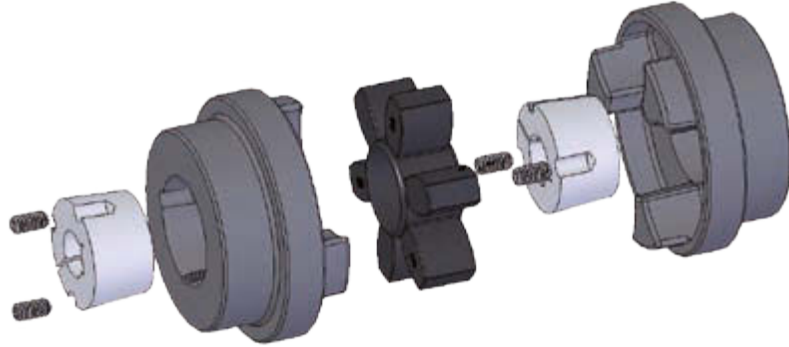

B flange

F flange

H flange

l

Size	B flange				bush	F and H flange				d_a mm	d_i mm	Installation length		
	pre. mm	D_1 (H7) ¹⁾ max. mm	l_1 mm	l_2 mm		min. mm	max. mm	l_1 mm	l_2 mm			FF FH HH mm	l	
													FB HB mm	BB mm
70	8	32	23.5	20	1008	10	25	23.5	20	69	60	65	65	65
90	10	42	30.0	26	1108	10	25	23.5	19.5	85	70	69.5	76	82.5
110	10	55	45.0	37	1610	14	40	26.5	18.5	112	100	82	100.5	119
130	15	60	47.5	39	1610	14	40	26.5	18.0	130	105	89	118	147
150	20	70	56.0	46	2012	14	50	33.5	23.5	150	115	107	133.5	160
180	25	80	70.0	58	2517	16	60	46.5	34.5	180	125	142	165.5	189
230	25	100	90.0	77	3020	25	75	52.5	39.5	225	155	164.5	202	239.5
280	30	115	105.5	90	3525	35	100	66.5	51.0	275	206	207.5	246.5	285.5

1) Drill holes H7 with keyway in accordance with DIN 6885/1; tolerance zone JS9 and set screws on the keyway

TAPER BUSHES

WITH KEYWAY ACC. TO DIN 6885/1

TOLERANCE JS9

Taper bush no.	Bore ø of available Taper bushes											
	mm											
1008	10	11	12	14	16	18	19	20	22	24	25	
1108	10	11	12	14	16	18	19	20	22	24	25	28*
1610/1615	14	16	18	19	20	22	24	25	28	30	32	35
	38	40	42*									
2012	14	16	18	19	20	22	24	25	28	30	32	35
	38	40	42	45	48	50						
2517	16	18	19	20	22	24	25	28	30	32	35	38
	40	42	45	48	50	55	60					
3020	25	28	30	32	35	38	40	42	45	48	50	55
	60	65	70	75								
3525	35	38	40	42	45	48	50	55	60	65	70	75
	80	85	90	95	100							

* These bore holes are with flat keyway in accordance with DIN 6885/3.

SELECTION

The torque of the machine T_{AN} is determined by: $T_{AN} [Nm] = 9550 \times \frac{P_{Motor} [kW]}{n [rpm]}$

This torque T_{AN} multiplied by a safety factor S depending on the application and the temperature factor S_T (see table page 7) gives the required nominal coupling torque T_{KN} .

Result: $T_{KN} \geq S \times S_T \times T_{AN}$

› In case that bigger shock or changing loads occur we recommend a revision according to DIN 740. An adequate calculation program is available. For such a revision the following information is required:

1. Kind of the driving machine
2. Kind of the driven machine
3. Power of driving and driven machines
4. Rotational speed of operation
5. Shock loads
6. Exciting loads
7. Moments of inertia of load- and driving sides
8. Starts per hour
9. Ambient temperature

DESIGN EXAMPLE FOR IEC STANDARD MOTORS

Dates of the plant

Driving machine:

Three-phase motor: 225 M

Power of the motor: $P = 45 \text{ kW}$

Rotation at speed: $n = 1500 \text{ rpm}$

Driven machine: mixer

Ambient temperature: $+50 \text{ °C}$

$$T_{AN} [Nm] = 9550 \times \frac{45 \text{ kW}}{1500 \text{ rpm}} = 287 \text{ Nm}$$

$$T_{KN} = 1.75 \times 1.5 \times 287 \text{ Nm} = 753 \text{ Nm}$$

Selection: HRC size 180

$$T_{KN} = 950 \text{ Nm}$$

ALLOCATION TO IEC MOTORS

Power P of the IEC motors and allocated HRC couplings									Shaft ends	
Size of the three-phase motor	3000 rpm		1500 rpm		1000 rpm		750 rpm		Form E DIN 748 part 3 d x l at speed approx.	
	P kw	HRC size	P kw	HRC size	P kw	HRC size	P kw	HRC size	3000 rpm	1500 rpm and less
56	0.09	70	0.06	70	0.037	70	-		9 x 20	
	0.12	70	0.09	70	0.045	70	-			
63	0.18	70	0.12	70	0.06	70	-		11 x 23	
	0.25	70	0.18	70	0.09	70	-			
71	0.37	70	0.25	70	0.18	70	0.09	70	14 x 30	
	0.55	70	0.37	70	0.25	70	0.12	70		
80	0.75	70	0.55	70	0.37	70	0.18	70	19 x 40	
	1.1	70	0.75	70	0.55	70	0.25	70		
90 S	1.5	70	1.1	70	0.75	70	0.37	70	24 x 50	
90 L	2.2	70	1.5	70	1.1	70	0.55	70	24 x 50	
100 L	3	90	2.2	90	1.5	90	0.75	90	28 x 60	
	-	-	3	90	-	-	1.1	90		
112 M	4	90	4	90	2.2	90	1.5	90	28 x 60	
132 S	5.5	110	5.5	110	3	110	2.2	110	38 x 80	
	7.5	110	-	-	-	-	-	-		
132 M	-	-	7.5	110	4	110	3	110	38 x 80	
	-	-	-	-	5.5	110	-	-		
160 M	11	130	11	130	7.5	130	4	130	42 x 110	
	15	130	-	-	-	-	5.5	130		
160 L	18.5	130	15	130	11	130	7.5	130	42 x 110	
180 M	22	130	18.5	130	-	-	-	-	48 x 110	
180 L	-	-	22	130	15	130	11	130	48 x 110	
200 L	30	150	30	150	18.5	150	15	150	55 x 110	
	37	150	-	-	22	150	-	-		
225 S	-	-	37	150	-	-	18.5	150	55 x 110	60 x 140
225 M	45	150	45	150	30	150	22	150	55 x 110	60 x 140
250 M	55	150	55	180	37	180	30	180	60 x 140	65 x 140
280 S	75	180	75	230	45	230	37	230	65 x 140	75 x 140
280 M	90	180	90	230	55	230	45	230	65 x 140	75 x 140
315 S	110	180	110	280	75	280	55	280	65 x 140	80 x 170
315 M	132	180	132	280	90	280	75	280	65 x 140	80 x 170
315 L	160	230	160	280	110	280	90	280	65 x 140	80 x 170
	200	230	200	280	132	280	110	280		
355 L	250	230	250	280	160	280	132	-		
	315	230	315	-	200	-	160	-	75 x 140	95 x 170
400 L	-	-	-	-	250	-	200	-		
	355	280	355	-	315	-	250	-	80 x 170	100 x 210
	400	280	400	-	--	-	--	-		

As proposed in the table for surface cooled three-phase motors with cage rotor acc. to DIN 42673, page1 (data for motor 56, 63, 71, 80, 315 L, 355 L, 400 L, see catalogue Siemens). This allocation is a preliminary selection for normal conditions of operation. For conditions of operation under shock and changing loads the selection must be made according to the following.

FLEXIBLE COUPLINGS

PEX

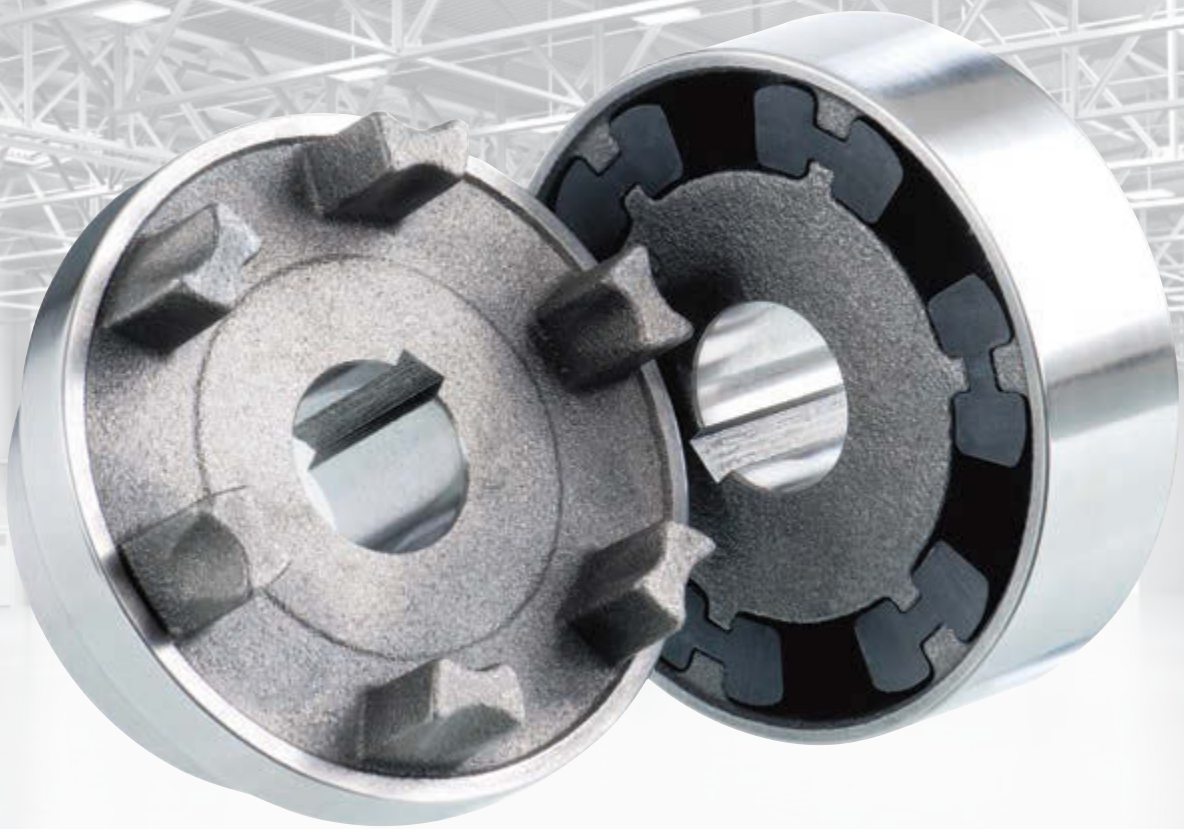

PEX

The flexible Pex couplings are claw couplings with flexible elements to provide a torsionally flexible connection of shafts. The flexible elements excel in their wear resistance, ageing resistance and their temperature resistance from -30°C to $+80^{\circ}\text{C}$. Thanks to their flexibility, impacts, rotary vibrations and noises are effectively absorbed. The flexible elements are dimensioned such that radial, axial and angular movements between the two halves of the coupling are cancelled out.

The flexible Pex couplings are of the plug-in type for installation and do not involve any particularly rigorous requirements with respect to alignment accuracy. Pex couplings can be used in the whole of machine construction wherever a reliable shaft connection is needed between motor and working machine.

TYPE A

The Pex type A coupling is manufactured in three-piece design. With this design it is possible to install packages without axial displacement of the drive engine or working machine.

TYPE B

The Pex type B coupling is fail-safe up to the fracture moment of the cast iron transmission cam and this provides maximum operational safety. The flexible elements can be supplied with hardness 80° Shore A. With the fixed position of the flexible elements its deformability in axial direction is free, and so no damaging axial forces can act on the machine bearing even with alternating torque.

WEAR INDICATOR

The wear indicator for Pex couplings enables the condition of the flexible elements to be easily assessed. The wear condition can also be ascertained with the aid of a stroboscope while the coupling is rotating. The production process can thus continue undisturbed. The wear indicator must be attached to the outside diameter of the coupling after the coupling has been fitted.



SELECTION

The torque of the machine T_{AN} is determined by: $T_{AN} [\text{Nm}] = 9550 \times \frac{P_{\text{Motor}} [\text{kW}]}{n [\text{rpm}]}$

This torque T_{AN} multiplied by a safety factor S depending on the application and the temperature factor S_T (see table page 5) gives the required nominal coupling torque T_{KN} .

Result: $T_{KN} \geq S \times S_T \times T_{AN}$

PEX - TYPE A

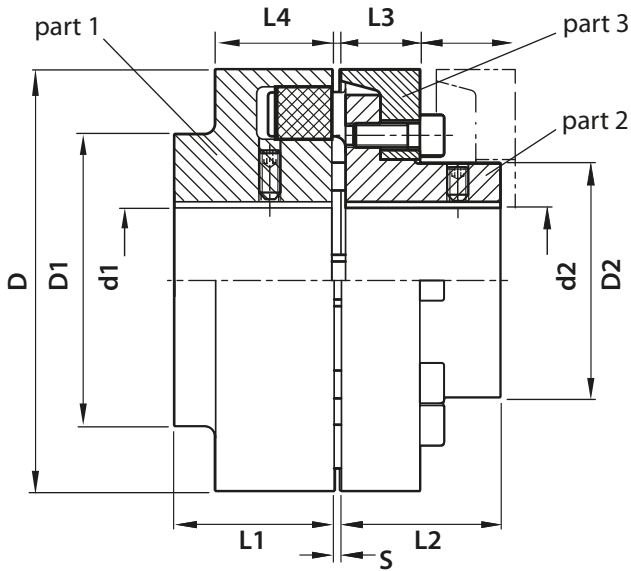
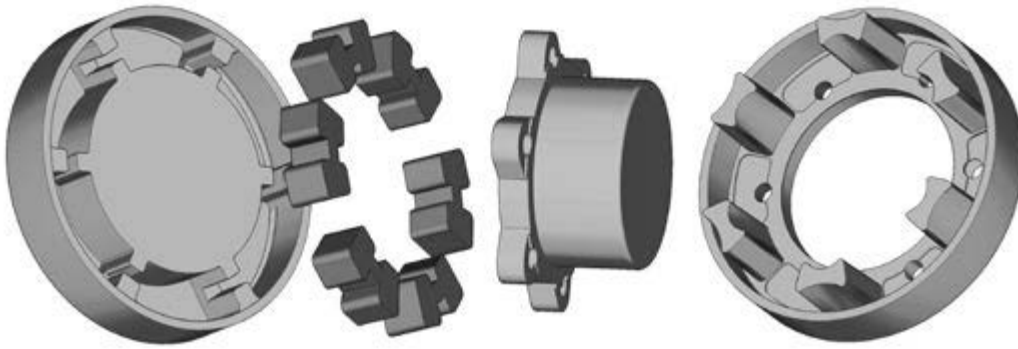

► Materials: Coupling half EN-GJL-250
Flexible elements NBR 80° Shore A

TYPE A

	Nominal torque Nm	Max. rotation speed rpm	Pre. bore		Max. bore		D	L1	L2	D1	D2	L3	L4	S	Weight ¹⁾ kg			Moments of inertia ¹⁾ kgm ²	Max. shaft misalignment at rotational speed n = 1500 rpm ²⁾		
			d1	d2	d1	d2									part 1	part 2	part 3		axial ↔ K _a mm	radial ↔ K _r mm	angular ↔ K _w °
110	160	5300	17	12	48	38	110	40	40	86	62	20	34	3	1.95	1.38	1.97	0.003	0.2	0.2	0.1
125	240	5100	18	15	55	45	125	50	50	100	75	23	36	3	3.05	2.42	1.97	0.005	0.25	0.25	0.1
140	360	4900	20	17	60	50	140	55	55	100	82	28	34	3	3.65	3.04	2.5	0.008	0.25	0.25	0.1
160	560	4250	25	20	65	58	160	60	60	108	95	28	39	4	5.05	4.19	3.49	0.014	0.3	0.3	0.1
180	880	3800	25	20	75	65	180	70	70	125	108	30	42	4	7.8	5.94	4.41	0.025	0.3	0.3	0.1
200	1340	3400	30	25	85	75	200	80	80	140	122	32	47	4	11	8.61	6.02	0.04	0.3	0.3	0.09
225	2000	3000	35	30	90	85	225	90	90	150	136	38	52	4	15	12.06	8.93	0.08	0.35	0.35	0.09
250	2800	2750	45	45	100	95	250	100	100	165	155	42	60	6	19.5	17.41	11.7	0.13	0.35	0.35	0.08

1) The information concerning weights and moments of inertia apply for medium holes.

2) The values mentioned are valid for n = 1500 rpm and may occur only separately. At multiple misalignments or higher speeds the values must be reduced.

PEX - TYPE B

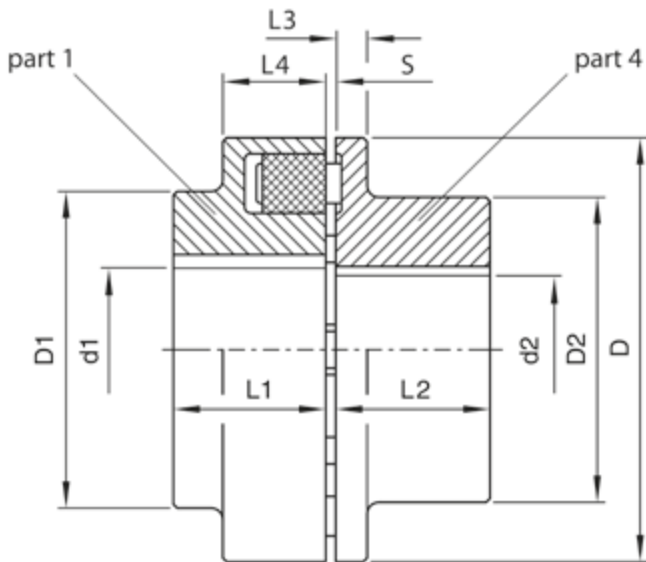
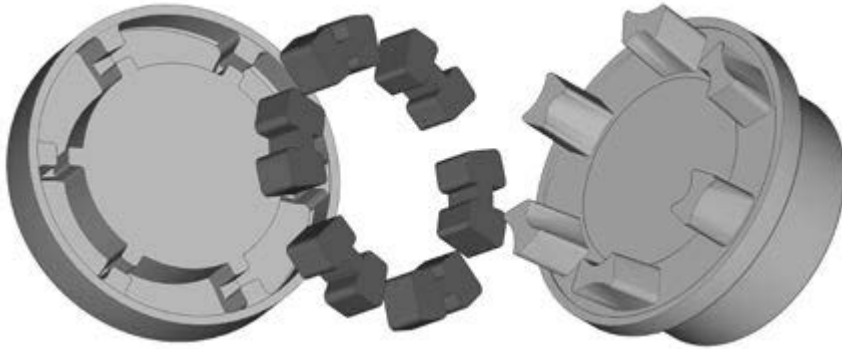

► Materials: Coupling half EN-GJL-250
Flexible elements NBR 80° Shore A

TYPE B

Size	Nominal torque Nm	Max. rotation speed rpm	Pre. bore		Max. bore		D	L1	L2	D1	D2	L3	L4	S	Weight ¹⁾ kg		Moments of inertia ¹⁾ kgm ²	Max. shaft misalignment at rotational speed n = 1500 rpm ²⁾		
			d1	d2	d1	d2									part 1	part 4		axial ~ K _s mm	radial ~ K _r mm	angular ~ K _w °
58	19	7500	-	-	19	24	58	20	20	-	40	8	20	3	0.24	0.28	0.0001	0.2	0.2	0.15
68	34	7000	-	-	24	28	68	20	20	-	50	8	20	3	0.32	0.45	0.0002	0.2	0.2	0.15
80	60	6000	12	12	30	38	80	30	30	-	68	10	30	3	0.75	0.94	0.0006	0.2	0.2	0.12
95	100	5500	12	12	42	42	95	35	35	76	76	12	30	3	1.3	1.55	0.0013	0.2	0.2	0.12
110	160	5300	17	17	48	48	110	40	40	86	86	14	34	3	1.95	2.25	0.003	0.2	0.2	0.1
125	240	5100	18	18	55	55	125	50	50	100	100	18	36	3	3.05	3.6	0.006	0.25	0.25	0.1
140	360	4900	20	20	60	60	140	55	55	100	100	20	34	3	3.65	4.5	0.007	0.25	0.25	0.1
160	560	4250	25	25	65	65	160	60	60	108	108	20	39	4	5.05	5.95	0.01	0.3	0.3	0.1
180	880	3800	25	25	75	75	180	70	70	125	125	20	42	4	7.8	8.5	0.02	0.3	0.3	0.1
200	1340	3400	30	30	85	85	200	80	80	140	140	24	47	4	11	12.4	0.04	0.3	0.3	0.09
225	2000	3000	35	35	90	90	225	90	90	150	150	18	52	4	15	15.5	0.07	0.35	0.35	0.09
250	2800	2750	45	45	100	100	250	100	100	165	165	18	60	6	19.5	19.5	0.12	0.35	0.35	0.08

1) The information concerning weights and moments of inertia apply for medium holes.

2) The values mentioned are valid for n = 1500 rpm and may occur only separately. At multiple misalignments or higher speeds the values must be reduced.

FLEXIBLE COUPLINGS

ORPEX®

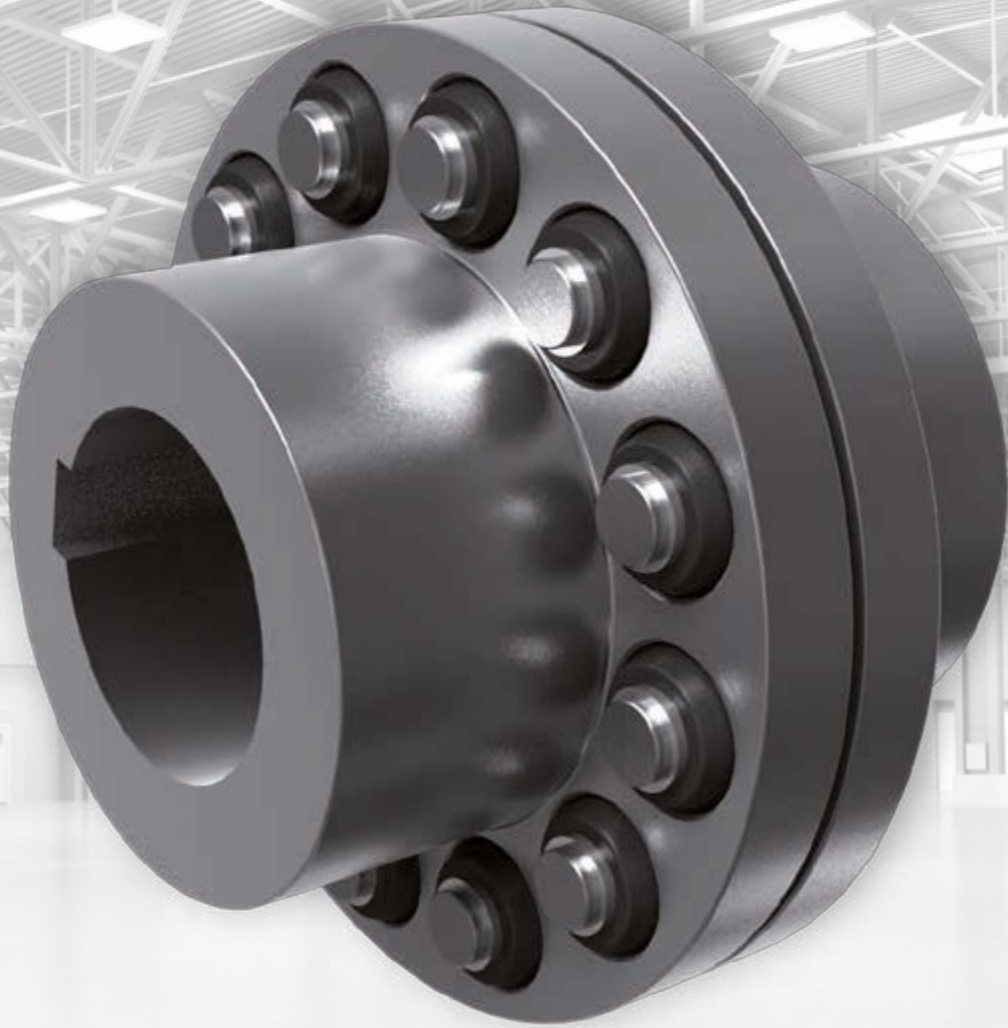

ORPEX®

Orpex® couplings are used as compensation couplings everywhere where an absolutely reliable torque transfer is required. Orpex® couplings cover with their types a wide range of uses. With a total of 26 sizes, couplings are available for torques from 200 to 1,300,000 Nm. The coupling halves of the type WN consist of grey cast iron. With the WS type of steel it is possible to use the coupling with high speeds. With the convex elastic elements which can be moved in the holes - the buffers - it is possible to compensate for the shaft offsets in angular, radial and axial direction. Orpex® couplings damp torque impacts and offer the possibility of shifting critical speeds. Orpex® couplings are fail-safe up to the fracture moment of the metal parts, which is a multiple of the permissible impact moment, and thus offers the greatest possible operational safety. Orpex® couplings can be used for both directions of rotation and are also suitable for reversing operation. The buffers can be expected to have a long life with correct design of the coupling and correct alignment of the assembly. Orpex® couplings can also be adapted in many ways to special requirement profiles.



TYPE

- > WN
- > WS

A large number of applications already created and tried are available for this. Our Projects Department would be pleased to advise you. Orpex® couplings have proven themselves over decades in all areas of mechanical engineering, especially in the case of heavy-duty drives, as an absolutely reliable and practically maintenance-free machine element.

FUNCTIONING

The positive torque transfer is achieved by means of elastic elements subjected exclusively to pressure which then deform elastically under compression. The progressive spring characteristic and the excellent damping properties of the buffers counteract the dangerous build-up of any rotary vibrations that occur.

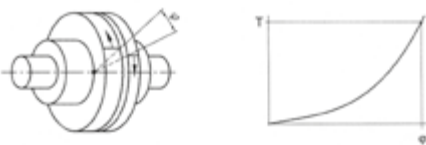

Torsion spring strips and torsional angles

The optimised round convex form of the buffers favours the compensatory function where angular or radial offsets are present and minimises restoring forces. The ground bolts are fastened with no play by means of a conical seat. This effectively prevents any possible widening of the locating hole and the development of frictional corrosion. The convex buffers of the Orpex® couplings can be mounted by plugging in. It is possible to replace the bolts and buffers without any axial displacement of the motor or the machines. Uncoupled machines can be dismantled radially. The buffers can be used at ambient temperatures of -30°C to +80°C. They are resistant by electrical conduction against oil and many other media.

TECHNICAL DETAILS

- > Perfect transfer of the torque and trouble-free functioning are only guaranteed when original Orpex® buffers are used.
- > The arrangement of the coupling parts of the types WN and WS on the shaft ends to be connected is discretionary. Both horizontal and vertical installation is possible.
- > Orpex® couplings are normally fitted with a feather key groove according to DIN 6885 part 1 and set screw. Design with wedge groove according to DIN 6886, tightening from inside of hub, is possible. Care must be taken here to ensure that the maximum allowable holes only amount to 60% of the maximum allowable holes with key feather groove according to DIN 6885 part 1.
- > Rotating parts must be secured by the purchaser to prevent un-intentional contact. When products are supplied to other countries the safety regulations applying there must be observed.
- > The shaft ends to be connected must be stored immediately in front of and behind the coupling.
- > We are at your service for design to DIN 740 part 2 and for vibration calculations. Vibration calculations can also be ordered from Engineering Service.
- > With respect to the installation and commissioning of Orpex® couplings the installation and operating instructions must be observed.



TYPE WN GREY CAST IRON

SIZE 105 TO 500

Size	$D_{1/2}^{(1)}$ min. mm	$D_1^{(1)}$ max. mm	$D_2^{(1)}$ max. mm	d_a mm	d_1 mm	d_2 mm	l mm	P mm	S mm	W mm	u mm
105	-	32	38	105	53	59	45	30	2...4	12	13
125	-	40	48	125	65	68	50	35	2...4	15	16
144	-	45	55	144	76	84	55	35	2...4	15	16
162	-	50	60	162	85	92	60	40	2...5	18	20
178	-	60	70	178	102	108	70	40	2...5	18	20
198	-	70	80	198	120	128	80	40	2...5	18	20
228	-	80	90	228	129	140	90	50	2...5	24	26
252	38	90	100	252	150	160	100	50	2...5	24	26
285	48	100	110	285	164	175	110	60	3...6	30	32
320	55	110	120	320	180	192	125	60	3...6	30	32
360	65	120	130	360	200	210	140	75	3...6	42	42
400	75	140	140	400	230	230	160	75	3...6	-	42
450	85	160	160	450	260	260	180	90	4...7	-	52
500	95	180	180	500	290	290	200	90	4...7	-	52

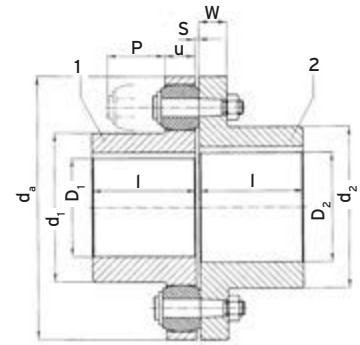

> Size 105-360

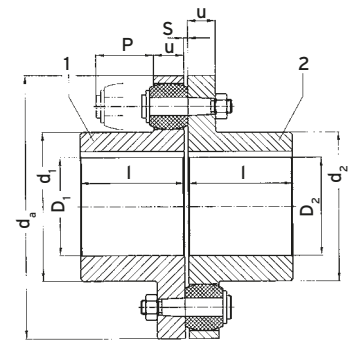

> Size 400

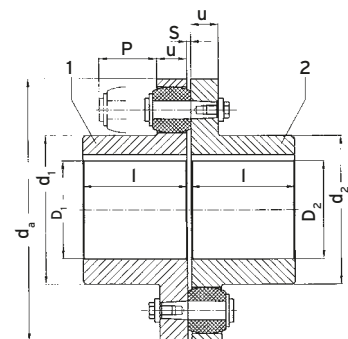

> Size 450-500

Size	Nominal torque ²⁾	Max. rotation speed rpm	Moments of inertia ³⁾ kgm ²		Weight ³⁾ kg	
	T_{KN} Nm		part 1	part 2	part 1	part 2
105	200	5000	0.001	0.001	0.96	1.2
125	350	5000	0.003	0.003	1.9	1.9
144	500	4900	0.004	0.006	2.2	3.1
162	750	4300	0.007	0.013	3.2	4.6
178	950	3800	0.014	0.022	4.8	6.7
198	1300	3400	0.023	0.031	7	8.6
228	2200	3000	0.04	0.074	9.1	14
252	2750	2700	0.07	0.12	13	18.5
285	4300	2400	0.13	0.22	19	26.5
320	5500	2100	0.23	0.31	27	35
360	7800	1900	0.42	0.71	37	52
400	12500	1700	0.89	0.89	60	60
450	18500	1500	1.7	1.7	89	89
500	25000	1350	2.8	2.8	115	115

- 1) Drill holes H7 with keyway in accordance with DIN 6885/1; tolerance zone JS9 and set screws on the keyway
- 2) Torques for shaft fit with keyway
- 3) The details of weight and moments of inertia apply for medium holes D_1 , D_2 .

TYPE WS STEEL

SIZE 105 TO 500

Size	$D_{1/2}^{(1)}$	$D_1^{(1)}$	$D_2^{(1)}$	d_a	d_1	d_2	l	P	S	W	u
	min. mm	max. mm	max. mm	mm	mm	mm	mm	mm	mm	mm	mm
105	-	32	38	105	53	59	45	30	2...4	12	13
125	-	40	48	125	65	68	50	35	2...4	15	16
144	-	50	60	144	76	84	55	35	2...4	15	16
162	-	55	65	162	85	92	60	40	2...5	18	20
178	-	70	75	178	102	108	70	40	2...5	18	20
198	-	80	85	198	120	128	80	40	2...5	18	20
228	-	85	95	228	129	140	90	50	2...5	24	26
252	38	100	110	252	150	160	100	50	2...5	24	26
285	48	110	120	285	164	175	110	60	3...6	30	32
320	55	125	130	320	180	192	125	60	3...6	30	32
360	65	135	140	360	200	210	140	75	3...6	42	42
400	75	150	150	400	230	230	160	75	3...6	-	42
450	85	170	170	450	260	260	180	90	4...7	-	52
500	95	190	190	500	290	290	200	90	4...7	-	52

Size	Nominal torque ²⁾	Max. rotation speed	Moments of inertia ³⁾		Weight ³⁾	
	T_{KN} Nm	rpm	kgm ²		kg	
			part 1	part 2	part 1	part 2
105	200	5000	0.001	0.001	0.96	1.2
125	350	5000	0.003	0.003	1.6	1.9
144	500	5000	0.004	0.006	2.2	3.1
162	750	5000	0.007	0.013	3.2	4.6
178	950	4900	0.014	0.022	4.8	6.7
198	1300	4600	0.023	0.031	7	8.6
228	2200	4400	0.04	0.074	9.1	14
252	2750	4200	0.07	0.12	13	18.5
285	4300	3900	0.13	0.22	19	26.5
320	5500	3500	0.24	0.33	27	35
360	7800	3100	0.42	0.71	37	52
400	12500	2800	0.95	0.95	63	63
450	18500	2500	1.8	1.8	93	93
500	25000	2200	2.9	2.9	125	125

1) Drill holes H7 with keyway in accordance with DIN 6885/1; tolerance zone JS9 and set screws on the keyway

2) Torques for shaft fit with keyway

3) The details of weight and moments of inertia apply for medium holes D_1 , D_2 .

SIZE 560 TO 2000

Size	D _{1/2} ¹⁾				WN	WN	WS	WN	WN	WN	WN	WN
	WN min. mm	WN max. mm	WS min. mm	WS max. mm	d _a mm	d _{1/2} mm	d _{1/2} mm	l mm	v mm	P mm	S mm	u mm
560	100	140	100	165	560	250	250	220	70	120	4...8	68
	> 140	180	> 165	200		300	300					
	> 180	200	> 200	210		320	320					
630	100	140	100	165	630	250	250	240	80	120	4...8	68
	> 140	180	> 165	200		300	300					
	> 180	200	> 200	235		355	355					
710	110	160	110	190	710	290	290	260	80	140	5...9	80
	> 160	200	> 190	220		330	330					
	> 200	240	> 220	250		385	385					
800	125	180	125	210	800	320	320	290	90	140	5...9	80
	> 180	220	> 210	240		360	360					
	> 220	260	> 240	280		420	420					
900	140	220	> 210	240	900	360	360	320	100	160	5...10	90
	> 220	260	> 240	280		425	425					
	> 260	290	> 280	310		465	465					
1000	150	240	> 230	260	1000	395	395	350	110	160	5...10	90
	> 240	280	> 260	300		460	460					
	> 280	320	> 300	340		515	515					
1120	160	200	160	270	1120	360	360	380	120	180	6...11	100
	> 200	250	> 240	300		410	410					
	> 250	300	> 270	360		495	495					
1250	180	230	180	270	1250	410	410	420	130	180	6...11	100
	> 230	280	> 270	300		460	460					
	> 280	330	> 300	360		540	540					
1400	200	260	200	310	1400	465	465	480	145	210	6...12	120
	> 260	320	> 310	350		525	525					
	> 320	380	> 350	410		620	620					
1600	260	320	260	370	1600	565	565	540	165	210	6...12	120
	> 320	380	> 370	410		625	625					
	> 380	440	> 410	480		720	720					
1800	320	380	320	440	1800	660	660	600	185	240	8...16	140
	> 380	440	> 440	480		720	720					
	> 440	500	> 480	540		820	820					
2000	380	440	380	500	2000	760	760	660	200	240	8...16	140
	> 440	500	> 500	540		820	820					
	> 500	560	> 540	610		920	920					
	> 560	600	> 610	640		960	960					

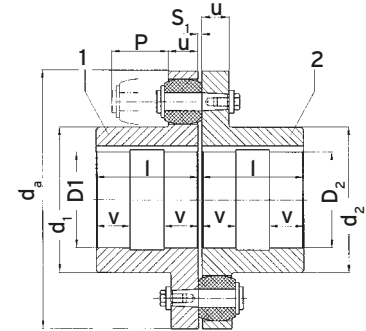

> Size 560-2000

- 1) Drill holes H7 with keyway in accordance with DIN 6885/1; tolerance zone JS9 and set screws on the keyway
- 2) Torques for shaft fit with keyway
- 3) The details of weight and moments of inertia apply for medium holes D₁, D₂.

SIZE 560 TO 2000

Size	Nominal torque ²⁾ WN / WS T _{KN} Nm	Max. rotation speed		Moments of inertia ³⁾		Weight ³⁾	
		WN	WS	WN 1/2 kgm ²	WS 1/2 kgm ²	WN 1/2 kg	WS 1/2 kg
560	39 000	1200	2000	4.6	4.8	145	150
				5	5.2	155	155
				5.1	5.4	150	155
630	52 000	1050	1800	7.2	7.6	180	190
				7.7	8	195	195
				8.4	8.8	210	210
710	8 000	950	1600	13	14.3	265	275
				14	14.7	270	275
				15	16	285	295
800	110 000	850	1400	22	23.3	350	370
				23	23.5	360	370
				24.5	26	380	400
900	150 000	750	1250		40		480
				39	41	500	480
				41	44	500	520
1000	195 000	680	1100	43	45	530	530
					63		620
				60	64	640	620
1120	270 000	600	1000	63	68	650	670
				68	71	680	700
				98	105	750	820
1250	345 000	550	900	100	106	780	830
				105	110	830	910
				110	120	880	950
1400	530 000	490	800	150	169	950	1050
				155	172	980	1100
				165	180	1050	1150
1600	750 000	430	700	175	190	1150	1250
				290	318	1450	1600
				300	323	1500	1600
1800	975 000	380	600	310	340	1600	1750
				330	360	1700	1850
				490	550	1950	2250
2000	1 300 000	340	550	500	560	2000	2250
				530	600	2150	2400
				550	620	2200	2450
1800	975 000	380	600	850	1050	2850	3300
				930	1075	2900	3300
				980	1130	3100	3500
2000	1 300 000	340	550	1050	1150	3200	3600
				1350	1640	3500	4300
				1400	1670	3600	4300
2000	1 300 000	340	550	1500	1750	3800	4600
				1550	1800	3900	4600

- 1) Drill holes H7 with keyway in accordance with DIN 6885/1; tolerance zone JS9 and set screws on the keyway
- 2) Torques for shaft fit with keyway
- 3) The details of weight and moments of inertia apply for medium holes D₁, D₂.

DESIGNS

SIZE 105 TO 360



➤ Arrangement of the bolts and buffers on one site

SIZE 400 TO 2000



➤ Arrangement of the bolts and buffers on alternating sites

ORPEX®

BOLTS AND BUFFERS

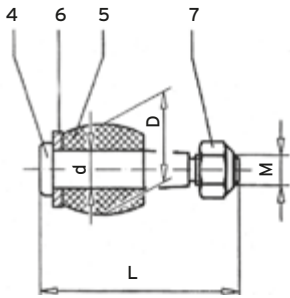

> 105-400

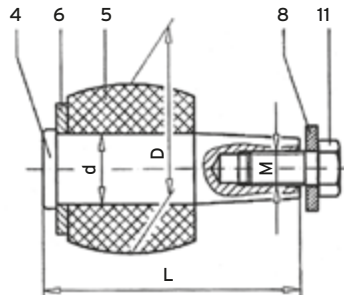

> 450-630

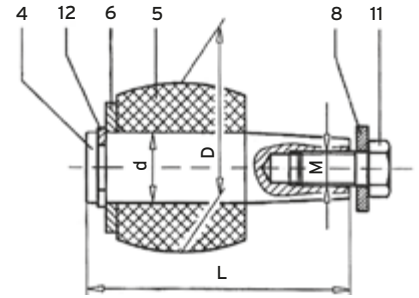

> 710-2000

Coupling size	Number per set	D mm	d mm	L mm	M mm
105	8	20	8	45	M6
125	8	24	10	53.5	M8
144	10	24	10	53.5	M8
162	9	30	12	64.5	M10
178	10	30	12	64.5	M10
198	12	30	12	64.5	M10
228	11	40	16	79	M12
252	12	40	16	79	M12
285	11	48	20	98	M16
320	12	48	20	98	M16
360	10	64	25	123	M18
400	14	64	25	123	M18
450	12	78	32	123	M16
500	14	78	32	123	M16
560	12	101	42	158	M20
630	14	101	42	158	M20
710	14	120	50	185.5	M24
800	16	120	50	185.5	M24
900	16	136	55	207.5	M24
1000	18	136	55	207.5	M24
1120	18	155	60	232.5	M30
1250	20	155	60	232.5	M30
1400	20	175	70	274	M30
1600	24	175	70	274	M30
1800	22	200	80	327	M36
2000	26	200	80	327	M36

ALIGNMENT

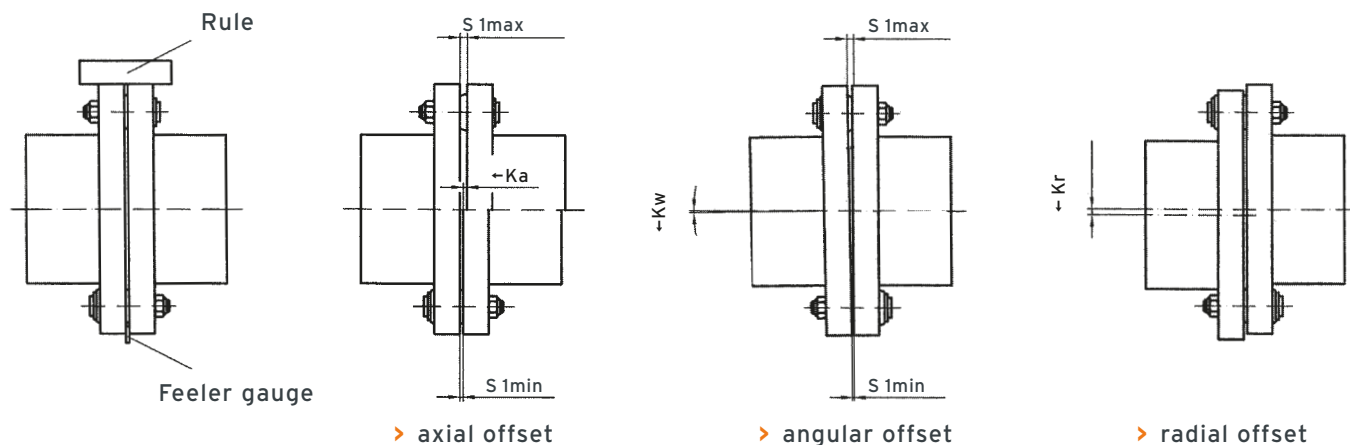

Offset of coupling parts in relation to one another may arise from an imprecise alignment during assembly, but also from operation of the machine (thermal expansion, shaft sag, excessively soft machine frame etc.).

Orpex® couplings absorb position deviations in the machines to be connected. When alignment is being performed the radial and angular offset of the shaft ends must be kept as small as possible, since this will lengthen the service life of the buffers under otherwise identical operating conditions. The coupling must be assembled and aligned in accordance with our operating instructions. The offset figures given as allowable in the table are intended for general guidance.

PERMITTED SHAFT MISALIGNMENT

The permitted shaft misalignment depends on the operating speed. As the speed increases, lower shaft misalignment values are permitted. The following table shows the correction factors for different speeds. The maximum speed for the respective coupling size and type must be observed!

$$\leftarrow K_{zul} = \leftarrow K_{1500} \cdot FKV$$

	Speed in rpm			
	500	1000	1500	3000
Correction factor FKV	1.60	1.20	1.0	0.70

The axial misalignment may occur dynamically at frequencies up to 10 Hz.

For fitting, a maximum gap dimension S_{max} and a minimum gap dimension S_{min} according to table page 11 is permitted.

Shaft misalignment $\leftarrow K_a$, $\leftarrow K_r$ und $\leftarrow K_w$ may occur simultaneously.

PERMITTED MISALIGNMENT

Size	Axial misalignment mm			Rotation speed n rpm	Angular and radial misalignment ¹⁾ mm		
	S_{1min}	S_{1max}	$\leftarrow K_a$ perm. $S_{1max} - S_{1min}$		$\leftarrow K_r$ perm.	$\leftarrow K_w$ $S_{1max} - S_{1min}$	$\leftarrow K_w$ perm. degree
105	2	4	2	1500	0.276		0.150
125	2	4	2		0.273		0.125
144	2	4	2		0.315		0.125
162	2	5	3		0.284		0.100
178	2	5	3		0.312		0.100
198	2	5	3		0.26		0.075
228	2	5	3		0.299		0.075
252	2	5	3		0.221		0.050
285	3	6	3		0.249		0.050
320	3	6	3		0.28		0.050
360	3	6	3		0.315		0.050
400	3	6	3		0.525		0.075
450	4	7	3	750	0.591		0.075
500	4	7	3		0.438		0.050
560	4	8	4		0.49		0.050
630	4	8	4		0.55		0.050
710	5	9	4		0.62		0.050
800	5	9	4		1.05		0.075
900	5	10	5	380	1.18		0.075
1000	5	10	5		0.875		0.050
1120	6	11	5		0.98		0.050
1250	6	11	5		1.09		0.050
1400	6	12	6	180	2.45		0.100
1600	6	12	6		2.1		0.075
1800	8	16	8		2.4		0.076
2000	8	16	8		2.6		0.074

1) The permitted angular and radial misalignment may be used singly, if they occur simultaneously only proportionally.

TECNAMIC

Dynamic Drive Technology

FLEXIBLE COUPLINGS

FLEX



FLEX

FLEX

FLEXIBLE FLEX COUPLINGS

The Flex coupling combines all the advantages which can be expected of an ideal flexible coupling. It is a torsional flexible coupling which offers a wide spectrum of cases of applications to the technical designers and the engineers by combining the different types of steel flanges for many different applications. Flex is a high flexible tyre coupling which can because of the special built tyre take an extreme big misalignment at a low restoring force in each direction without noticing this in the wear. Because of a factory-installed joint the tyre can according to standard be radially assembled and disassembled without shifting the connected engines. The transmission of the torque takes place absolutely free from backlash. Thanks to the flexibility of the coupling, impacts, rotary vibrations and noises are effectively absorbed. The tyre with fabric inside is either made of natural rubber or of chloroprene in fire-resistant, antistatic and oil-resistant execution, short called FRAS-execution. The FRAS-tyre is also used in duties with Ex-operations according to the EC directive. Tyres made of natural rubber are suitable for ambient temperatures between -50°C and $+50^{\circ}\text{C}$. Tyres in FRAS-execution are suitable for ambient temperatures between -15°C and $+70^{\circ}\text{C}$.



TYPE

- > Standard coupling for finish bore
- > Taper bush type
- > Combined type standard/taper
- > Components can be combined as needed

FLEXIBLE FLEX COUPLINGS WITH TAPER BUSH

The Flex coupling combines the advantages of the elastic couplings with those of the taper bush system: fast and simple assembly of a torsionally flexible connection of shafts and compensation for shaft alignment errors. Flex couplings with taper bush have the advantage that even with greater shaft tolerances there is a backlash-free and at the same time axial fixing of the shaft. In addition the close sliding fit makes axial alignment of the coupling easier.

FLEX FLANGE B, F, H

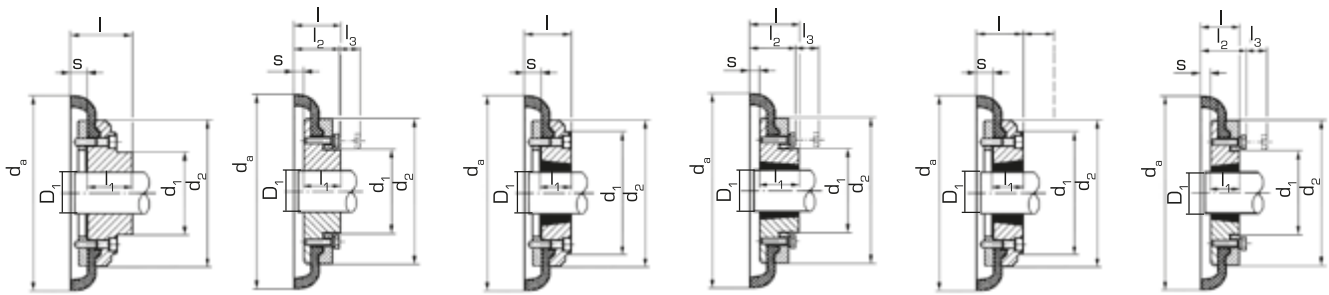

> B flange
40-60

70-250

> F flange
40-60

70-250

> H flange
40-60

70-250

Size	Pre. bored	B flange					F flange					H flange					d _a	d ₂	l ₂	l ₃	s
		D ₁ (H7) ¹⁾	d ₁	l	l ₁	Bush	D ₁ max.	d ₁	l	l ₁	Bush	D ₁ max.	d ₁	l	l ₁						
		mm	mm	mm	mm	mm	mm	mm	mm	mm	mm	mm	mm	mm	mm						
D 40	12	30	-	33	22	1008	25	-	33	22	1008	25	-	33	22	104	82	-	-	11	
D 50	15	38	79	45	32	1210	32	79	38	25	1210	32	79	38	25	133	100	-	-	12.5	
D 60	18	45	70	55	38	1610	42	70	42	25	1610	42	70	42	25	165	125	-	-	16.5	
D 70	22	50	80	47	35	2012	50	80	44	32	1610	42	80	42	25	187	144	50	13	11.5	
D 80	25	60	97	55	42	2517	60	95	58	45	2012	50	97	45	32	211	167	54	16	12.5	
D 90	28	70	112	63.5	49	2517	60	108	59.5	45	2517	60	108	59.5	45	235	188	60	16	13.5	
D 100	32	80	125	70.5	56	3020	75	120	65.5	51	2517	60	113	59.5	45	254	216	62	16	13.5	
D 110	30	90	128	75.5	63	3020	75	134	63.5	51	3020	75	134	63.5	51	279	233	62	16	12.5	
D 120	38	100	143	84.5	70	3525	100	140	79.5	65	3020	75	140	65.5	51	314	264	67	16	14.5	
D 140	75	130	178	110.5	94	3525	100	178	81.5	65	3525	100	178	81.5	65	359	311	73	17	16	
D 160	75	140	187	117	102	4030	115	197	92	77	4030	115	197	92	77	402	345	78	19	15	
D 180	75	150	200	137	114	4535	125	205	112	89	4535	125	205	112	89	470	398	94	19	23	
D 200	85	150	200	138	114	4535	125	205	113	89	4535	125	205	113	89	508	429	103	19	24	
D 220	85	160	218	154.5	127	5040	125	223	129.5	102	5040	125	223	129.5	102	562	474	118	20	27.5	
D 250	85	190	254	161.5	132	-	-	-	-	-	-	-	-	-	-	628	532	125	25	27.5	

1) Drill holes H7 with keyway in accordance with DIN 6885/1; tolerance zone JS9 and set screws on the keyway

TECHNICAL DATA

Size	Max. rotation speed rpm	Torque ¹⁾ Nm			Torsion spring rigidity dyn Nm/rad	Relative damping ψ	Moments of inertia ³⁾ kgm ²	Weight ³⁾	Max. shaft misalignment ⁴⁾		
		nominal T_{KN}	max. T_{kmax}	changing $T_{Kw}^{2)}$					radial ΔK_r mm	axial ΔK_a mm	angular ΔK_w mm
D 40	4500	24	64	11	285	0.9	0.00148	1.6	1.1	1.3	5.7
D 50	4500	66	160	26	745	0.9	0.0023	2.4	1.3	1.7	7
D 60	4000	127	318	53	1500	0.9	0.0104	4.0	1.6	2.0	8.7
D 70	3600	250	487	81	2350	0.9	0.018	6.2	1.9	2.3	10
D 80	3100	375	759	127	3600	0.9	0.036	9.8	2.1	2.6	12
D 90	3000	500	1096	183	5200	0.9	0.062	14.0	2.4	3.0	13
D 100	2600	675	1517	252	7200	0.9	0.11	20.0	2.6	3.3	15
D 110	2300	875	2137	356	10 000	0.9	0.156	23.5	2.9	3.7	16
D 120	2050	1330	3547	591	17 000	0.9	0.274	33.0	3.2	4.0	18
D 140	1800	2325	5642	940	28 000	0.9	0.51	45.0	3.7	4.6	22
D 160	1600	3770	9339	1556	44 500	0.9	0.849	68.0	4.2	5.3	24
D 180	1500	6270	16 455	2742	78 500	0.9	1.718	92.0	4.8	6.0	28
D 200	1300	9325	23 508	3918	110 000	0.9	2.582	112.0	5.3	6.6	30
D 220	1100	11600	33 125	5521	160 000	0.9	4.246	152.0	5.8	7.3	33
D 250	1000	14 675	42 740	7124	200 000	0.9	7.01	208.0	6.6	8.2	37

1) Torques for shaft fit with keyway

2) Maximum alternating torque up to $f = 10$ Hz

3) The details of weight and moments of inertia apply for medium holes.

4) The values mentioned may occur only separately. At multiple misalignments the values must be reduced (see page 5).

TAPER BUSHES WITH KEYWAY ACC. TO DIN 6885/1

Taper bush no.	Bore \varnothing of available taper bushes mm											
	10	11	12	14	16	18	19	20	22	24*	25*	
1008	10	11	12	14	16	18	19	20	22	24*	25*	
1210	10	11	12	14	16	18	19	20	22	24	25	28
	30	32										
1610	14	16	18	19	20	22	24	25	28	30	32	35
	38	40	42*									
2012	14	16	18	19	20	22	24	25	28	30	32	35
	38	40	42	45	48	50						
2517	16	18	19	20	22	24	25	28	30	32	35	38
	40	42	45	48	50	55	60	65*				
3020	25	28	30	32	35	38	40	42	45	48	50	55
	60	65	70	75								
3525	35	38	40	42	45	48	50	55	60	65	70	75
	80	85	90	95	100*							
4030	40	42	45	48	50	55	60	65	70	75	80	85
	90	95	100	105	110	115*						
4535	55	60	65	70	75	80	85	90	95	100	105	110
	115	120	125									
5040	70	75	80	85	90	95	100	105	110	115	120	125

> Tolerance JS9



* These bore holes are with flat keyway in accordance with DIN 6885/3.

ALLOWABLE MISALIGNMENTS

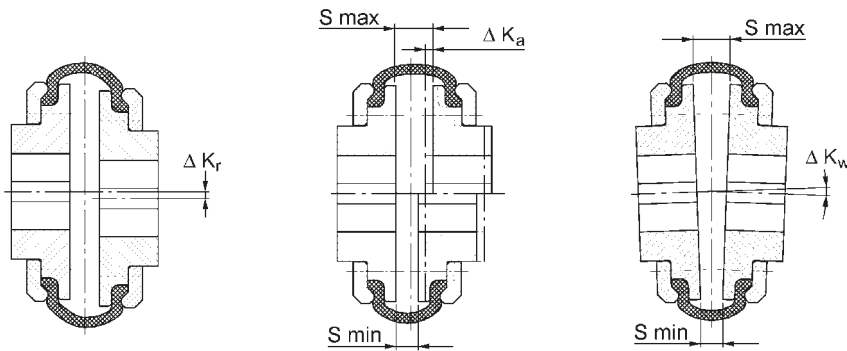

> $\leftarrow K_{r/a/w}$ = allowable radial, axial or angular misalignment of the shafts resp. of the coupling halves

Radial misalignment

Axial misalignment

Angular misalignment

- > The values given for $\leftarrow K_w$ [mm] = $S_{max} - S_{min}$ (see page 4) correspond to an angular offset of $\leftarrow K_w = 4^\circ$. This permissible angular shaft offset is the largest angular offset of the coupling halves, which may only be fully utilised if there is no axial and radial offset. An angular offset of $\leftarrow K_w = 2^\circ$ is permissible if axial and radial offsets of $1/2 \leftarrow K_a$ and $1/2 \leftarrow K_r$ are present.

SELECTION

- > The torque of the machine T_{AN} is determined by: $T_{AN} [Nm] = 9550 \times \frac{P_{Motor} [kW]}{n [rpm]}$

This torque T_{AN} multiplied by a safety factor S depending on the application gives the required nominal coupling torque T_{KN} .

Result: $T_{KN} \cong S \times T_{AN}$

- > In case that bigger shock or changing loads occur we recommend a revision according to DIN 740. An adequate calculation program is available. For such a revision the following information is required:
 1. Kind of the driving machine
 2. Kind of the driven machine
 3. Power of driving and driven machines
 4. Rotational speed of operation
 5. Shock loads
 6. Exciting loads
 7. Moments of inertia of load- and driving sides
 8. Starts per hour
 9. Ambient temperature

DESIGN EXAMPLE FOR IEC STANDARD MOTORS

Dates of the plant

Driving machine:
 Three-phase motor: Size 280S
 Power of the motor: P = 75 kW
 Rotation at speed: n = 1500 rpm
 up to 50 start-ups per hour
 Driven machine: mixer
 Ambient temperature: +25 °C

Layout of the coupling

$T_{AN} [Nm] = 9550 \times \frac{75 \text{ kW}}{1500 \text{ rpm}} = 478 \text{ Nm}$
 $T_{KN} = 2.5 \times 478 \text{ Nm} = 1195 \text{ Nm}$
 (S = 1.75 as per table + 0.75 for start-up frequency greater than 25)
 Selection: Flex D 120
 $T_{KN} = 1330 \text{ Nm}$

ALLOCATION TO IEC MOTORS

Size of the three-phase motor	Power P of the IEC motors and allocated Flex								Shaft ends	
	3000 rpm		1500 rpm		1000 rpm		750 rpm		Form E DIN 748 part 3 d x l at speed approx.	
	P kw	Flex size	P kw	Flex size	P kw	Flex size	P kw	Flex size	3000 rpm	1500 rpm and less
56	0.09	D40	0.06	D40	0.037	D40	-	-	9 x 20	
	0.12	D40	0.09	D40	0.045	D40	-	-		
63	0.18	D40	0.12	D40	0.06	D40	-	-	11 x 23	
	0.25	D40	0.18	D40	0.09	D40	-	-		
71	0.37	D40	0.25	D40	0.18	D40	0.09	D40	14 x 30	
	0.55	D40	0.37	D40	0.25	D40	0.12	D40		
80	0.75	D40	0.55	D40	0.37	D40	0.18	D40	19 x 40	
	1.1	D40	0.75	D40	0.55	D40	0.25	D40		
90 S	1.5	D50	1.1	D50	0.75	D50	0.37	D50	24 x 50	
90 L	2.2	D50	1.5	D50	1.1	D50	0.55	D50	24 x 50	
100 L	3	D50	2.2	D50	1.5	D50	0.75	D50	28 x 60	
	-	-	3	D50	-	-	1.1	D50		
112 M	4	D50	4	D50	2.2	D50	1.5	D50	28 x 60	
132 S	5.5	D60	5.5	D60	3	D60	2.2	D60	38 x 80	
	7.5	D60	-	-	-	-	-	-		
132 M	-	-	7.5	D60	4	D60	3	D60	38 x 80	
	-	-	-	-	5.5	D60	-	-		
160 M	11	D70	11	D70	7.5	D70	4	D70	42 x 110	
	15	D70	-	-	-	-	5.5	D70		
160 L	18.5	D70	15	D70	11	D70	7.5	D70	42 x 110	
180 M	22	D70	18.5	D70	-	-	-	-	48 x 110	
180 L	-	-	22	D70	15	D80	11	D80	48 x 110	
200 L	30	D80	30	D80	18.5	D80	15	D80	55 x 110	
	37	D80	-	-	22	D80	-	-		
225 S	-	-	37	D90	-	-	18.5	D90	55 x 110	60 x 140
225 M	45	D80	45	D100	30	D100	22	D100	55 x 110	60 x 140
250 M	55	D80	55	D100	37	D100	30	D100	60 x 140	65 x 140
280 S	75	D80	75	D110	45	D110	37	D120	65 x 140	75 x 140
280 M	90	D90	90	D120	55	D120	45	D120	65 x 140	75 x 140
315 S	-	-	110	D120	75	D120	55	D120	65 x 140	80 x 170
315 M	-	-	132	D140	90	D140	75	D140	65 x 140	80 x 170
315 L	-	-	160	D140	110	D140	90	D140	65 x 140	
	-	-	200	D140	132	D140	110	D160		
355 L	-	-	250	D160	160	D160	132	D180	75 x 140	
	-	-	315	D160	200	D160	160	D180		
	-	-	-	-	250	D160	200	D180		
400 L	-	-	355	D180	315	D180	250	D180	80 x 170	100 x 210
	-	-	400	D180	-	-	-	-	-	-

- As proposed in the table for surface cooled three-phase motors with cage rotor acc. to DIN 42673, page 1 (data for motor 56, 63, 71, 80, 315 L, 355 L, 400 L, see catalogue Siemens). This allocation is a preliminary selection for normal conditions of operation. For conditions of operation under shock and changing loads the selection must be made according to page 5.

SAFETY FACTOR S

Assignment of load characteristics according to type of working machine			
S	DREDGERS	S	RUBBER MACHINERY
S	Bucket conveyor	M	Extruders
M	Landing gear (caterpillar)	S	Calenders
M	Landing gear (rail)	M	Kneading mills
M	Manoeuvring winches	S	Mixers
S	Pumps	S	Rolling mills
S	Impellers		
S	Cutter heads		WOOD WORKING MACHINES
M	Slewing gear	S	Barkers
		M	Planing machines
		G	Wood working machines
		S	Saw frames
M	GENERATORS, TRANSFORMERS		
M	Frequency transformers		CRANES
M	Generators	G	Luffing gear block
M	Welding generators	S	Travelling gear
		G	Hoist gear
		M	Slewing gear
		M	Derricking jib gear
M	CHEMICAL INDUSTRY		
M	Cooling drums		PLASTIC INDUSTRY MACHINES
G	Mixers	M	Extruders
M	Agitators (liquid material)	M	Calenders
M	Agitators (semi-liquid material)	M	Mixers
M	Drying drums	M	Crushers
G	Centrifuges (light)		
M	Centrifuges (heavy)		METAL WORKING MACHINES
		M	Plate bending machines
M	OIL INDUSTRY	S	Plate straightening machines
S	Pipeline pumps	S	Hammers
	Rotary drilling equipment	S	Metal planning machines
		S	Presses
M	CONVEYORS	M	Shears
S	Pit-head winches	S	Forging presses
M	Winding engines	S	Punch presses
M	Jointed-band conveyors	G	Countershafts, line shafts
G	Belt conveyors (bulk material)	M	Machine tools (main drives)
M	Belt conveyors (piece goods)	G	Machine tools (auxiliary drives)
M	Band pocket conveyors		
M	Chain conveyors		FOOD INDUSTRY MACHINERY
M	Circular conveyors	G	Bottling and container filling machines
M	Load elevators	M	Kneading machines
G	Bucket conveyors for flour	M	Mash tubs
M	Passenger lifts	G	Packaging machines
M	Plate conveyors	M	Cane crushers
M	Screw conveyors	M	Cane cutters
M	Ballast elevators	S	Cane mills
S	Inclined hoists	M	Sugar beet cutters
M	Steel belt conveyors	M	Sugar beet washing machines
M	Drag chain conveyors		
			PAPER MACHINES
M	BLOWERS, VENTILATORS	S	Couches
G	Rotary piston blowers	S	Glazing cylinders
M	Blowers (axial/radial)	M	Pulper
M	Cooling tower fans	S	Pulp grinders
M	Induced draught fans	M	Calenders
G	Turbo blowers	S	Wet presses
		S	Willows
		S	Suction presses
		S	Suction rolls
		S	Drying cylinders
S	BUILDING MACHINERY		
G	Hoists		PUMPS
S	Concrete mixers		Piston pumps
	Road construction machinery		G
			Centrifugal pumps (light liquids)
			M
			Centrifugal pumps (viscous liquids)
			S
			Plunger pumps
			S
			Press pumps
			STONE AND CLAY WORKING MACHINES
		S	Crusher
		S	Rotary ovens
		S	Hammer mills
		S	Ball mills
		S	Tube mills
		S	Beater mills
		S	Brick presses
			TEXTILE MACHINES
		M	Batchers
		M	Printing and dyeing machines
		M	Tanning vats
		M	Willows
		M	Looms
			COMPRESSORS
		S	Piston compressors
		M	Turbo compressors
			METAL ROLLING MILLS
		S	Plate shears
		M	Manipulator for turning sheets
		S	Ingot pushers
		S	Ingot and slabbing-mill train
		S	Ingot handling machinery
		M	Wire drawing benches
		S	Descaling machines
		S	Thin plate mills
		S	Heavy and medium plate mills
		M	Winding machines (strip and wire)
		S	Cold rolling mills
		M	Chain tractor
		S	Billet shears
		M	Cooling beds
		M	Cross tractor
		M	Roller tables (light)
		S	Roller tables (heavy)
		M	Roller straighteners
		S	Tube welding machines
		M	Trimming shears
		S	Cropping shears
		S	Continuous casting plant
		M	Rollers adjustment drive
		S	Manipulators
			LAUNDRIES
		M	Tumblers
		M	Washing machines
			WATER TREATMENT
		M	Aerators
		M	Screw pumps

Operating factor S			
Driving machines	Load characteristics of the working machine		
	G	M	S
Electric motors, turbines, hydraulic motors	1	1.75	2.5
Piston machines 4-6 cylinders, degree of nonuniformity 1:100 - 1:200	1.25	2	2.75
Piston machines 1-3 cylinders, degree of nonuniformity up to 1:100	1.5	2.25	3

- > The operating factor S takes account of up to 25 start-ups per hour.
- > With up to 120 start-ups per hour the factor S must be increased by 0.75.

RIGID COUPLINGS

GC
GC-ECO



GC

Gear couplings GC are flexible shaft connections suitable for a positive torque transmission. They ensure to compensate radial, axial and angular shaft misalignments. The gear couplings are made of high quality tempered steel with grease lubrication and O-ring seal.

Gear couplings GC are used in all areas of mechanical engineering and offer a long service life with maximum reliability, resulting from the optimal grease lubrication of the crowned spline. The couplings are generally suitable for a horizontal assembly. Special types are suitable for vertical assembly, too.

The range of gear couplings includes sizes from 50 to 1000 with torque transmissions from 1920 Nm to 8 000 000 Nm, these are suitable for shaft diameters from 20 mm to 1000 mm.

Special types, adapted to your application requirements, are possible in a short delivery time!



TYPE

- > High quality heavy duty coupling
- > Special types are possible in short delivery times

TOOTH PRINCIPLE

The crowned spline principle results in case of angular and radial misalignment the avoidance of edge pressure in the spline. Optimal friction conditions of the spline with an almost wear-free operation, resulting due to the permanent grease lubrication, lead to a long service life expectancy of the coupling.



GEAR COUPLINGS GC TYPES

 <p>GC - standard coupling GC 50 - GC 220</p>	 <p>GCL - with extended hubs</p>
 <p>GC - standard coupling - large sizes GC 240 - GC 600</p>	 <p>GCT - with shear pins</p>
 <p>GCY - with one-piece sleeve</p>	 <p>GCB - with brake disc</p>
 <p>GCLE - with intermediate shaft</p>	 <p>GCV - for vertical assembly</p>
 <p>GCX - with spacer sleeve</p>	 <p>GCTAM - special type for assembly in winder</p>

FURTHER TYPES AVAILABLE ON REQUEST!

GEAR COUPLINGS GC

SIZE 50-220

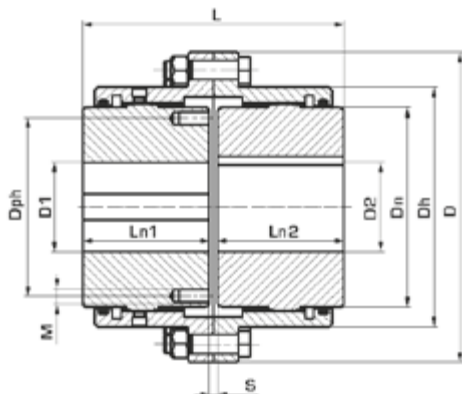

SIZE 240-600

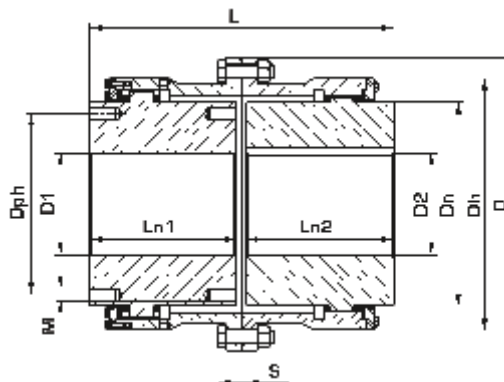

Size	D	D _{max}	D _h	D _n	D1/D2 min.	D1/D2 max.	L _{min}	L	L _{max}	L _{n min}	L _{n1} /L _{n2}	L _{n max}	S	S1	S2	D _{ph}	M
	mm		mm	mm	mm		mm			mm			mm	mm	mm	mm	mm
50	111	250	83	64	20	50	91	93	208	43	45	100	3	8	10	57	M5
65	148	250	105	83	20	65	131	136	316	50	65	150	6	20	26	72	M8
75	169	250	126	100	20	75	151	156	316	62	75	150	6	18	23	88	M8
100	209	300	162	135	30	100	171	176	316	76	85	150	6	17	23	120	M10
120	233	300	186	160	40	120	211	216	416	90	105	200	6	24	34	144	M10
135	254	300	204	175	40	135	231	236	418	100	115	200	6	24	44	156	M12
150	308	400	246	200	50	150	241	246	618	105	120	300	6	27	44	168	M16
165	336	500	262	220	60	165	301	310	628	120	150	300	10	58	83	196	M16
190	366	500	303	255	80	190	341	350	828	150	170	400	10	47	83	228	M20
220	428	600	345	290	80	220	401	410	828	175	200	400	10	50	94	246	M20
240	458	600	394	320	80	240	463	476	844	190	230	400	16	99	170	284	M20
270	490	600	436	360	120	270	503	516	844	220	250	400	16	94	162	314	M24
285	534	800	474	380	120	285	563	576	844	250	280	400	16	121	213	330	M24
330	580	800	518	431	160	330	603	616	844	280	300	400	16	101	173	390	M30
365	668	800	586	480	180	365	705	730	858	325	350	400	30	137	233	422	M30
400	730	1000	642	530	200	400	805	830	358	345	400	450	30	131	213	478	M30
450	830	1000	720	621	200	450	805	830	358	400	400	450	30	131	213	560	M30
500	882	1000	742	651	200	500	905	930	1058	410	450	500	30	141	230	600	M30
600	970	1000	867	761	300	600	1005	1030	1070	470	500	500	30	151	230	680	M30
700	1220	2000	1064	921	300	700	1405	1440	1710	580	700	800	40	-	-	830	M42
800	1440	2000	1240	1061	300	800	1405	1440	1710	600	700	800	40	-	-	920	M48
900	1600	2000	1416	1190	400	900	1505	1540	1710	680	750	800	40	-	-	1100	M48
1000	1814	2000	1630	1350	500	1000	1660	1700	2380	740	800	1100	100	-	-	1160	M48

The diameters D_n and D_h are locked.

Other dimensions can be chosen for special types according to the range given.

TECHNICAL DATA

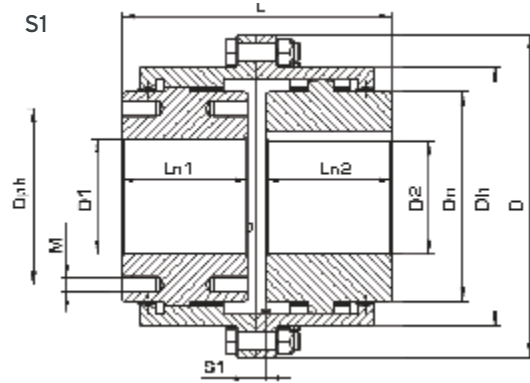
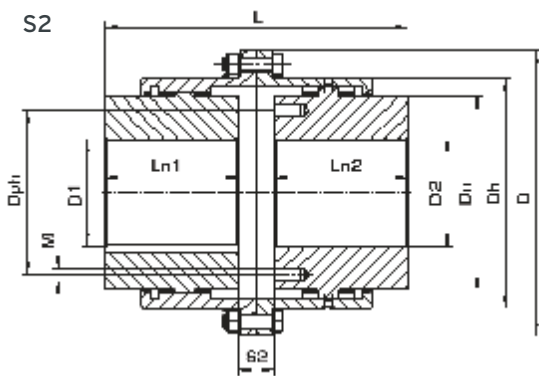

Size	Torque Nm		Max. speed rpm	Weight ¹⁾ kg	Moments of inertia ¹⁾ J kgm ²	Max. shaft misalignment ²⁾		S _{min} S _{max}		S1 _{min} S1 _{max}		S2 _{min} S2 _{max}	
	nominal T _{KN}	max. T _{kmax}				radial Δ K _r mm	angular Δ K _w degree	mm		mm		mm	
50	1920	3840	8700	3.60	0.005	0.45	1	1	8	5	10	7	12
65	3550	7100	6700	8.70	0.022	0.69	1	1	16	15	24	20	32
75	6100	12200	5200	13	0.044	0.76	1	1	16	13	22	18	28
100	13600	27200	4200	25	0.139	0.84	1	1	16	12	21	18	28
120	18900	37800	3600	37	0.270	1.10	1	1	16	17	31	24	44
135	25300	50600	3250	47	0.380	1.23	1	1	18	15	33	24	64
150	35500	71000	2800	70	0.868	1.23	1	1	18	20	33	24	64
165	38600	77200	2600	103	1.50	1.73	1	1	28	52	63	58	108
190	78000	156000	2200	148	2.74	1.85	1	1	28	36	58	58	108
220	110600	221200	1950	215	5.32	2.27	1	1	28	33	66	64	124
240	156000	312000	1750	324	9.68	2.73	1	3	44	86	111	155	185
270	186000	372000	1600	415	14.9	2.92	1	3	44	81	106	148	176
285	219000	438000	1450	540	23.7	3.43	1	3	44	111	131	198	228
330	250500	501000	1300	717	36.8	3.61	1	3	44	91	111	158	188
365	345000	690000	1150	927	61	4.19	1	5	58	124	150	216	250
400	470000	940000	1050	1299	102	6.68	1.5	5	58	112	150	192	234
450	661000	1322000	950	1712	172	6.68	1.5	5	58	112	150	192	234
500	790000	1580000	900	2214	252	7.46	1.5	5	58	122	160	210	250
600	1250000	2500000	775	3242	488	8.25	1.5	5	70	131	170	230	270
700	2150000	4300000	650	6054	1358	9.00	2	5	110	-	-	-	-
800	3600000	7200000	550	9014	2744	9.00	2	5	110	-	-	-	-
900	5300000	10600000	475	11866	4574	9.00	2	5	110	-	-	-	-
1000	8000000	16000000	425	13500	6691	9.00	2	60	180	-	-	-	-

1) Weight and moments of inertia apply for max. bore diameter.

2) The values mentioned are valid for n max. = 1500 rpm.

GEAR COUPLINGS GC

MISALIGNMENT

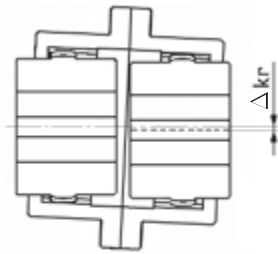

- Radial misalignment is given at the maximum allowed angular misalignment and according to the shortest value S, S1, S2 - table page 4.

Radial misalignment

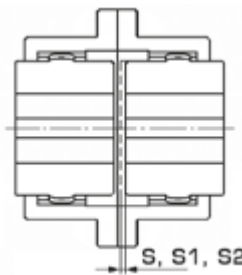

Axial misalignment

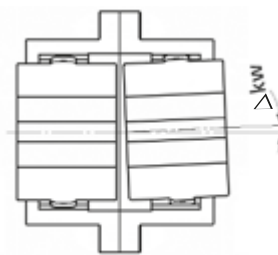

Angular misalignment

The size of a coupling for a specific drive depends not only on the driving power and the rotational speed, but also on the angular misalignment and the type of machine to be connected.

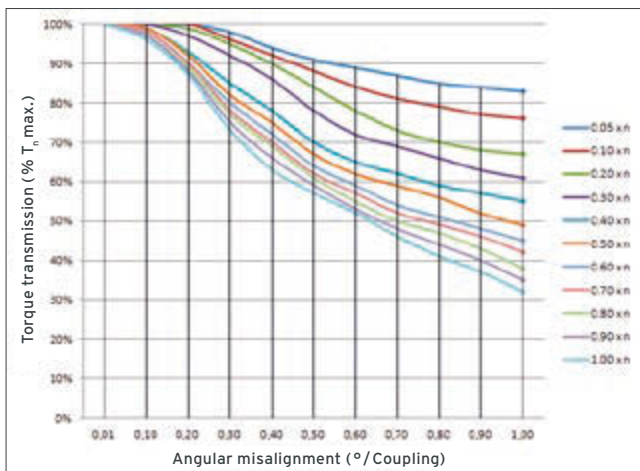

- Torque transfer of the coupling in relation to increasing angular misalignment and rotational speed

GC

GC-ECO

Gear couplings GC-ECO are economic and torsionally stiff shaft connections suitable for a positive torque transmission. They ensure the flexible compensation of shaft misalignments as well. The gear coupling is made of high tensile steel with grease lubrication and O-ring seal.

Gear couplings GC-ECO are used in all areas of mechanical engineering and offer a long service life with maximum reliability, resulting from the optimal grease lubrication of the crowned spline. The couplings are generally suitable for a horizontal assembly. Special types are suitable for vertical assembly, too.

The range of gear couplings ECO includes standard sizes from 52 to 280 with torque transmissions from 1900 Nm to 200 000 Nm, these are suitable for shaft diameters from 20 mm to 280 mm. Bigger shaft diameters and higher torques are possible on request.

Special types, adapted to your application requirements, are possible in a short delivery time!



TYPE

- Economic standard coupling
- Special types are possible in short delivery times

GEAR COUPLINGS GC-ECO

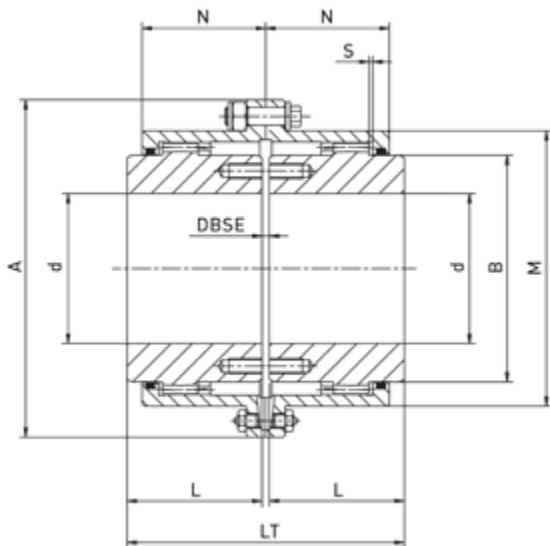

GCE

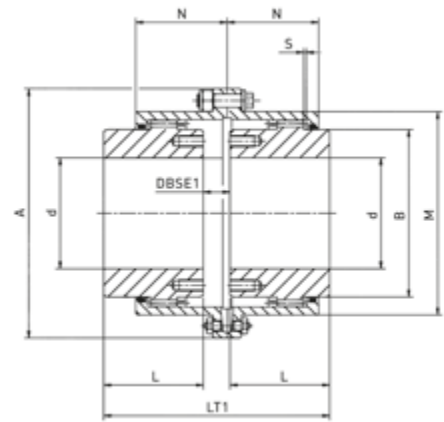

GCER

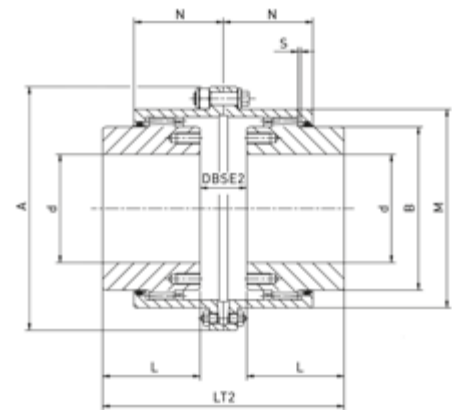

GCERR

Size	d _{max} mm	A mm	M mm	B mm	L mm	L1 mm	LT mm	LT1 mm	LT2 mm	LT3 mm	LT4 mm	N mm	Y mm	DBSE mm	DBSE1 mm	DBSE2 mm
52	52	111	82.5	68	43	105	89	91	93	151	213	39	12	3	5	7
62	62	142	104.6	86	50	115	103	108	113	168	233	45.5	16	3	8	13
78	78	168	130.5	105	62	130	127	138	149	195	263	59	22	3	14	25
98	98	200	158.4	132	76	150	157	170	184	231	305	68	26	5	18	32
112	112	225	183.4	151	90	170	185	204	223	265	345	82.5	38	5	24	43
132	132	265	211.5	179	105	185	216	237	258	296	376	93	45	6	27	48
156	156	300	245.5	209	120	215	246	272	298	296	436	106	50	6	32	58
174	174	330	275	234	135	245	278	307	336	341	498	118	58	8	37	66
190	190	370	307	255	150	295	308	350	392	388	598	138	70	8	50	92
210	210	406	335	280	175	300	358	403	448	453	608	154	80	8	53	98
233	233	439	367	306	190	305	388	438	488	483	618	166	86	8	58	108
280	280	505	423	356	220	310	450	512	574	540	630	193	96	10	72	134

GC

TECHNICAL DATA

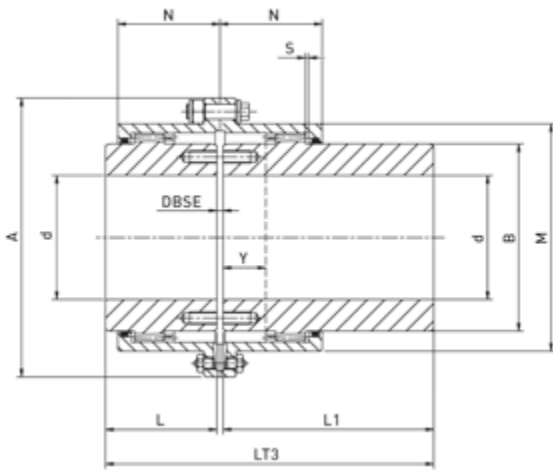

GCEL

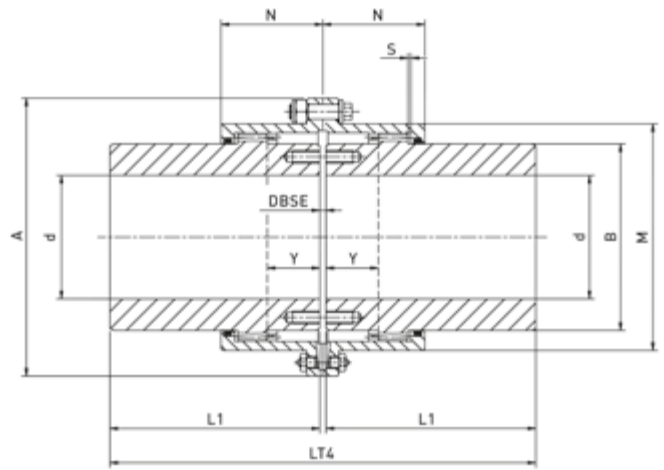

GCELL

Size	Torque		Max. speed rpm	GCE weight kg	GCEL weight kg	GCELL weight kg
	T_k Nm	$T_{max.}$ Nm				
52	1900	3800	6000	4.2	6.15	8
62	2900	5800	4550	7.6	10.2	13
78	5700	11400	4000	13.5	18.2	23
98	9000	18000	3900	25	33	41
112	14500	29000	3700	37	48.5	60
132	22800	45600	3550	60	56.5	91
156	34800	69600	3000	90	115	141
174	45800	91600	2750	124	161	199
190	70800	141600	2420	170	227	285
210	85400	170800	2270	233	292	352
233	150000	300000	1950	298	363	428
280	200000	400000	1730	457	526	596

SELECTION

➤ For the selection of a GC coupling the following information is required:

- PN Motor power respectively input power (kW)
- n Operating speed (rpm)
- L, d Length and diameter of the shafts (mm)
- S Safety factor, table page 11

Where required other geometrical or environmental restrictions.

➤ The torque of the machine T_{AN} is determined by:

$$T_{AN} [\text{Nm}] = 9550 \times \frac{P_{\text{Motor}} [\text{kW}]}{n [\text{rpm}]}$$

This torque T_{AN} multiplied by a safety factor S depending on the application and the temperature factor S_T (see table page 11) gives the required nominal coupling torque T_{KN} .

$$\text{Result: } T_{KN} \geq S \times S_T \times T_{AN}$$

➤ The coupling must be selected with a nominal torque T_{KN} higher than the calculated value. Furthermore must be checked that the peak torque of the application is lower than the max. torque T_{Kmax} of the coupling.

Torque transfer regarding angular misalignment and rotational speed acc. to diagram page 6 must be checked.

➤ In case that bigger shock or changing loads occur we recommend a revision according to DIN 740. An adequate calculation program is available. For such a revision the following information is required:

1. Kind of the driving machine
2. Kind of the driven machine
3. Power of driving and driven machines
4. Rotational speed of operation
5. Shock loads
6. Exciting loads
7. Moments of inertia of load- and driving sides
8. Starts per hour
9. Ambient temperature

SELECTION EXAMPLE FOR IEC STANDARD MOTORS

GIVEN DATA OF THE APPLICATION

Driving machine: electric motor
 Power of the motor: $P = 400 \text{ kW}$
 Rotation at speed: $n = 500 \text{ rpm}$
 Driven machine: rotary furnace

$$T_{AN} [\text{Nm}] = 9550 \times \frac{400 \text{ kW}}{500 \text{ rpm}} = 7640 \text{ Nm}$$

$$T_{KN} = 2.5 \times 7640 \text{ Nm} = 19100 \text{ Nm}$$

Selection: GC size 150

$$T_{KN} = 35500 \text{ Nm}$$

SAFETY FACTOR S

Assignment of load characteristics according to type of working machine

S	DREDGERS	S	RUBBER MACHINERY	S	PUMPS
S	Bucket conveyor	M	Extruders	G	Piston pumps
M	Landing gear (caterpillar)	S	Calenders	M	Centrifugal pumps (light liquids)
M	Landing gear (rail)	M	Kneading mills	S	Centrifugal pumps (viscous liquids)
M	Manoeuvring winches	S	Mixers	S	Plunger pumps
S	Pumps		Rolling mills	S	Press pumps
S	Impellers				
S	Cutter heads		WOOD WORKING MACHINES		STONE AND CLAY WORKING MACHINES
M	Slewing gear	S	Barkers		Crusher
		M	Planing machines	S	Rotary furnace
		G	Wood working machines	S	Hammer mills
		S	Saw frames	S	Ball mills
M	BUILDING MACHINERY			S	Tube mills
M	Hoists		CRANES	S	Beater mills
M	Concrete mixers	G	Luffing gear block	S	Brick presses
M	Road construction machinery	S	Travelling gear		
		G	Hoist gear		TEXTILE MACHINES
		M	Slewing gear	M	Batchers
		M	Derricking jib gear	M	Printing and dyeing machines
				M	Tanning vats
M	CHEMICAL INDUSTRY		PLASTIC INDUSTRY MACHINES	M	Willows
M	Cooling drums	M	Extruders	M	Looms
G	Mixers	M	Calenders		
M	Agitators (liquid material)	M	Mixers		COMPRESSORS
M	Agitators (semi-liquid material)	M	Crushers	S	Piston compressors
M	Drying drums			M	Turbo compressors
G	Centrifuges (light)		METAL WORKING MACHINES		
M	Centrifuges (heavy)	M	Plate bending machines		METAL ROLLING MILLS
			Plate straightening machines	S	Plate shears
M	OIL INDUSTRY	S	Hammers	M	Manipulator for turning sheets
S	Pipeline pumps	S	Metal planning machines	S	Ingot pushers
	Rotary drilling equipment	M	Presses	S	Ingot and slabbing-mill train
		S	Shears	S	Ingot handling machinery
M	CONVEYORS	S	Forging presses	M	Wire drawing benches
S	Pit-head winches	G	Punch presses	S	Descaling machines
M	Winding engines	M	Countershafts, line shafts	S	Thin plate mills
M	Jointed-band conveyors	M	Machine tools (main drives)	S	Heavy and medium plate mills
G	Belt conveyors (bulk material)	G	Machine tools (auxiliary drives)	M	Winding machines (strip and wire)
M	Belt conveyors (piece goods)			S	Cold rolling mills
M	Band pocket conveyors	G	FOOD INDUSTRY MACHINERY	M	Chain tractor
M	Chain conveyors	M	Bottling and container filling machines	S	Billet shears
M	Circular conveyors	M	Kneading machines	M	Cooling beds
M	Load elevators	G	Mash tubs	M	Cross tractor
G	Bucket conveyors for flour	M	Packaging machines	M	Roller tables (light)
M	Passenger lifts	M	Cane crushers	S	Roller tables (heavy)
M	Plate conveyors	S	Cane cutters	M	Roller straighteners
M	Screw conveyors	M	Cane mills	S	Tube welding machines
M	Ballast elevators	M	Sugar beet cutters	M	Trimming shears
S	Inclined hoists	M	Sugar beet washing machines	S	Cropping shears
M	Steel belt conveyors			S	Continuous casting plant
M	Drag chain conveyors	S	PAPER MACHINES	M	Rollers adjustment drive
		S	Couches	S	Manipulators
		M	Glazing cylinders		
M	BLOWERS, VENTILATORS	M	Pulper		LAUNDRIES
G	Rotary piston blowers	S	Pulp grinders	M	Tumblers
M	Blowers (axial/radial)	M	Calenders	M	Washing machines
M	Cooling tower fans	S	Wet presses		
M	Induced draught fans	S	Willows		WATER TREATMENT
G	Turbo blowers	S	Suction presses	M	Aerators
		S	Suction rolls	M	Screw pumps
		S	Drying cylinders		
S	GENERATORS, TRANSFORMERS				
G	Frequency transformers				
S	Generators				
	Welding generators				

Driving machines	Operating factor S		
	Load characteristics of the working machine		
	G	M	S
Electric motors, turbines	1.5	2	2.5
Hydraulic motors	2	2.5	3
Combustion motors	2.5	3	3.5

RIGID COUPLINGS

MINI



MINI

FEATURES

The Mini coupling is a backlash-free, torsion proof, bending elastic and, above all, maintenance-free steel coupling made in one piece. It is ideally suited for drive systems that control and manage highly dynamical processes in confined spaces. This situation can be found in the whole machine construction sector. Transfer lines, robots, medical technology and model making also count among the fields of application. The slot structure design results in positive cushioning effects and accounts for the desired vibrancy stability, but these are only some of the advantages of the Mini coupling. Another of its strengths is a very good axial, radial and angular flexibility when adjusting misalignments with low reset forces. The Mini coupling is easy to install - there are mounting possibilities on the shafts via clamping hubs or removable clamping hubs. Furthermore, a variety of hub designs is available, taking into account all sorts of applications and mounting situations.

The Mini coupling is made of high quality aluminium (Al), stainless steel (VA) or machining steel (St). It is unreservedly suitable for operations at temperatures ranging from -55°C to $+150^{\circ}\text{C}$. A deployment at higher temperatures is possible after clearance with our technical department.



TYPE MWK

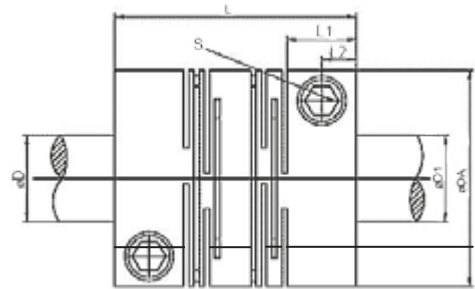

Dimensions in mm							
Size	L	L1	L2	D	D1	DA	S DIN 912
16	23	7	3.5	3-6	3-6	16	M2.5 x 6
18	16.6	5.5	2.75	3-6	3-6	18	M2.5 x 8
20	28	8	4	3-8	3-8	20	M2.5 x 8
22	20	5.5	2.75	3-10	3-10	22	M2.5 x 8
25	28	8	4	6-12	6-12	25	M3 x 10
30	40	11	5.5	6-14	6-14	30	M4 x 10
40	48	11	5.5	6-19	6-19	40	M5 x 14
50	65	19	9.5	10-26	10-26	50	M6 x 16
60	80	25	12.5	10-30	10-30	60	M8 x 18
70	95	25	12.5	15-35	15-35	70	M8 x 25
80	100	25	12.5	20-40	20-40	80	M8 x 25

Technical data													
Size	Torque T_{KN} Nm			Rotational speed rpm	Misalignment ²⁾			Torsional stiffness 10 ⁴ Nm/Rad			Weight ³⁾ g		
	AI ¹⁾	VA ¹⁾	St ¹⁾		angle °	axial mm	radial mm	AI ¹⁾	VA ¹⁾	St ¹⁾	AI ¹⁾	VA ¹⁾	St ¹⁾
16	3	-	-	10000	1	+0.3	+0.2	0.3	-	-	10	28	-
18	3	6	-	10000	1	+0.3	+0.2	0.4	0.7	-	5	18	-
20	5	12	-	9500	1	+0.3	+0.2	0.5	0.8	-	15	45	-
22	3	6	-	9500	1	+0.3	+0.2	0.6	0.9	-	12	40	-
25	7	16	-	8000	1	+0.3	+0.2	3.5	5	-	25	75	-
30	10	25	-	6000	1	+0.4	+0.3	5	8.5	-	50	160	-
40	19	36	-	5000	1	+0.4	+0.3	11.5	20	-	115	340	-
50	35	73	-	5000	1	+0.5	+0.3	35	55	-	250	650	-
60	70	-	125	4500	1	+0.5	+0.3	70	-	95	500	-	1350
70	130	-	170	4000	1	+0.5	+0.3	95	-	120	750	-	1890
80	180	-	220	3500	1	+0.5	+0.3	100	-	135	1040	-	3080

1) to 3) for explanation see page 4

TYPE MWH

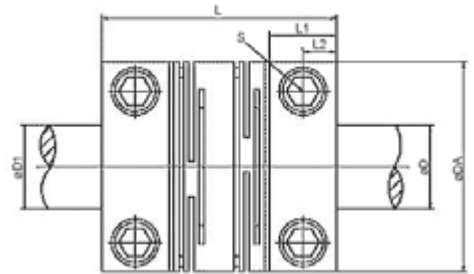

Dimensions in mm							
Size	L	L1	L2	D	D1	DA	S DIN 912
30	40	11	5.5	6-14	6-14	30	M4 x 10
40	48	11	5.5	6-19	6-19	40	M5 x 14
50	65	19	9.5	10-26	10-26	50	M6 x 16
60	80	25	12.5	10-30	10-30	60	M8 x 18
70	95	25	12.5	15-35	15-35	70	M8 x 25
80	100	25	12.5	20-40	20-40	80	M8 x 25

Technical data													
Size	Torque T_{KN} Nm			Rot. speed rpm	Misalignment ²⁾			Torsional stiffness 10+ Nm/Rad			Weight ³⁾ g		
	Al ¹⁾	VA ¹⁾	St ¹⁾		angle °	axial mm	radial mm	Al ¹⁾	VA ¹⁾	St ¹⁾	Al ¹⁾	VA ¹⁾	St ¹⁾
30	10	25	-	6000	1	+0.4	+0.3	5	8.5	-	50	160	-
40	19	36	-	5000	1	+0.4	+0.3	11.5	20	-	115	340	-
50	35	73	-	5000	1	+0.5	+0.3	35	55	-	250	650	-
60	70	-	125	4500	1	+0.5	+0.3	70	-	95	500	-	1350
70	130	-	170	4000	1	+0.5	+0.3	95	-	120	750	-	1890
80	180	-	220	3500	1	+0.5	+0.3	100	-	135	1040	-	3080

- 1) Material: aluminium alloy (Al) or stainless steel (VA), as of size 60: machining steel (St)
 - 2) The maximum permissible parameters are as stated above and they may only appear individually.
If multiple misalignments occur, a reduction has to be made.
 - 3) Concerns unbored couplings
- › Bore with groove according to DIN 6885 possible on demand!

SPECIAL TYPES

> This coupling system is available with many various hub versions, since it is used in various coupling applications with very different installation circumstances.

The difference among the versions is only the form.

The characteristics of couplings, like torque transmission capacity, compensation of the shaft misalignment and suchlike, are of course guaranteed.

<p>Design for threaded shaft Type MWM</p>	<p>Design with hollow shaft Type MWT</p>	<p>Design with hollow shaft (isolating) Type MWTI</p>
---	--	---

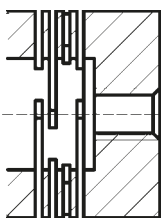

- Control systems
- Positioning systems
- Rotating tables, agitator systems
- Medical equipment

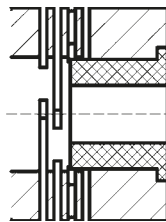

- Shaft encoder
- Gearing with hollow shafts

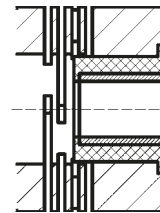

- Shaft encoder
- Solar power stations

<p>Design for flatted shaft (D shafts) Type MWD</p>	<p>Design with spreader shaft Type MWS</p>	<p>Design with threaded end Type MWZ</p>
---	--	--

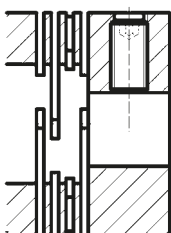

- Shaft encoder and engines with D shaft
- Incremental transmitter
- Positioning systems

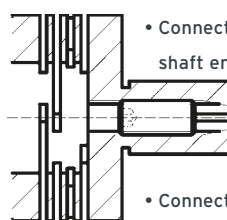

- Connections with planet gear, shaft encoder
- Connection with hollow shafts
- Tunnel mounting

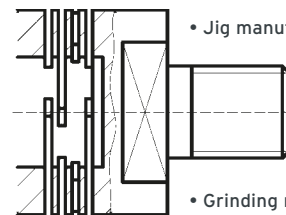

- Jig manufacturing
- Grinding machines
- Conveyors systems
- Small, grinding and boring machines

ALLOWABLE MISALIGNMENTS

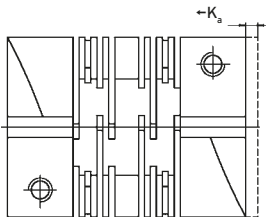

Axial misalignment

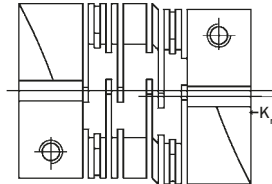

Radial misalignment

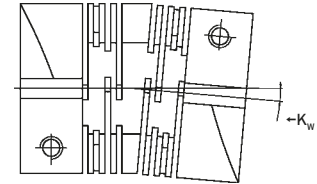

Angular misalignment

- Reduction of the allowable values of misalignment of the shafts when the combination of misalignments occurs

or at other rotational speeds:
$$\frac{\Delta W_r}{\Delta K_r} + \frac{\Delta W_a}{\Delta K_a} + \frac{\Delta W_w}{\Delta K_w} \leq 1$$

$\Delta K_{r/a/w}$ = allowable radial, axial or angular misalignment of the shafts resp. of the coupling halves

$\Delta W_{r/a/w}$ = measured radial, axial or angular misalignment of the shafts resp. of the coupling halves

SELECTION

- The torque of the machine T_{AN} is determined by:

$$T_{AN} [\text{Nm}] = 9550 \times \frac{P_{\text{Motor}} [\text{kW}]}{n [\text{rpm}]}$$

- This torque T_{AN} multiplied by a safety factor S depending on the application gives the required nominal coupling torque T_{KN} .

$$\text{Result: } T_{KN} \geq S \times T_{AN}$$

Operating factor S	
Uniform load	1
Irregular load	1.5
Heavy shock	2

- In case that bigger shock or changing loads occur we recommend a revision according to DIN 740.

An adequate calculation program is available. For such a revision the following information is required:

1. Kind of the driving machine
2. Kind of the driven machine
3. Power of driving and driven machines
4. Rotational speed of operation
5. Shock loads
6. Exciting loads
7. Moments of inertia of load- and driving sides
8. Starts per hour
9. Ambient temperature

RIGID COUPLINGS

CLAMP AND FLANGE COUPLING



CLAMP AND FLANGE COUPLING

FLANGE COUPLINGS DIN 116

Flange couplings are torsionally stiff, particularly sturdy and reliable shaft connections which can withstand jolts and radially or axially acting loads. The connected shafts must be precisely aligned. The flange couplings form C are equipped with a hollow for axial thrust washers according to DIN 28135 (applied, for example, with vertical agitator shafts). Axial thrust washers are not supplied and must be ordered separately. The connection dimensions of the flange couplings are in accordance with DIN 116, the centring of the coupling parts is achieved, however, only by means of fitting bolts. Normal design with feather key groove according to DIN 6885/1. Key slot according to DIN 6886 or DIN 6887 on request. In the case of shaft connections with different shaft diameters the coupling size assigned to the largest shaft diameter is used (reducing coupling).

- > Horizontal arrangement: form A
- > Vertical arrangement: form C
- > Material: normal design EN-GJL according to DIN EN 1561. On request in steel up to size 100 and in cast steel from size 110.

CLAMP COUPLINGS DIN 115

Clamp couplings are torsionally stiff and reliable shaft connections which can withstand jolts and radially or axially acting loads. The connected shafts must be precisely aligned. With the two shells which are bolted together the couplings are very easy to assemble and are therefore ideally suitable for shafts connected in series (e. g. transmission shafts).

When connecting shafts with different diameters we recommend that the thicker shaft end be offset on the diameter of the thinner one. If this is not possible the model with offset hole corresponding to the larger shaft diameter is used (form B). Clamp couplings can also be supplied with a protective jacket of sheet steel (form AS; BS or CS). All clamp couplings have feather key groove according to DIN 6885/1.

- > Horizontal arrangement:
 - Form A for shaft ends with same diameters
 - Form B for shaft ends with different diameters



- > Clamp couplings DIN 115
- > Flange couplings DIN 116
- > Clamp couplings 2-piece design
- > Clamp couplings 1-piece design

- > Vertical arrangement:
 - Form A with suspension key according to DIN 28134
 - Form C with ring inserts according to DIN 115 Sheet 2
- > Material: normal design EN-GJL according to DIN EN 1561. GS-45 on request.

PLEASE NOTE:

For shaft connections with rigid couplings the shafts must be precisely aligned. In order to avoid any excessive bending load on the coupling bearing must be mounted on both sides of the coupling where long shafts or high rotational speeds are involved.

CLAMP COUPLING 1-PIECE DESIGN

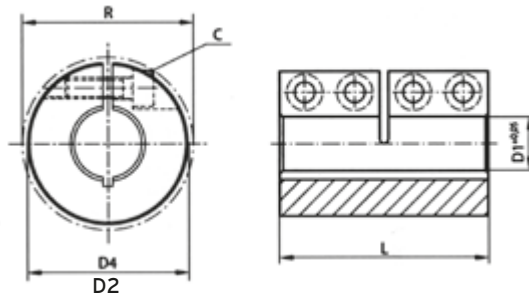

CLAMP COUPLING 2-PIECE DESIGN

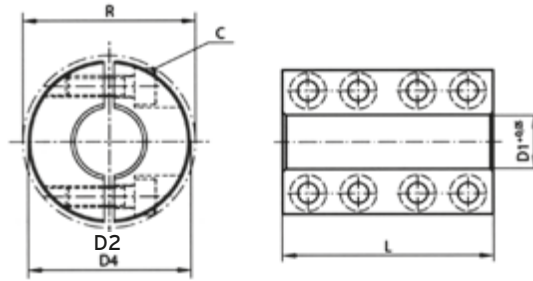

- › Material, design: steel 1.0718, black-oxidized; stainless steel 1.4305, blank

STEEL / STAINLESS STEEL

Size D1	Nominal torque Steel Nm	Nominal torque Stainless steel Nm	Dimensions in mm			C DIN 912-12.9	Weight ca. kg
			D2	L	R		
8	50	16	24	35	26.8	M3 x 8	0.10
10	85	25	29	45	32.7	M4 x 12	0.19
12	105	32	29	45	32.7	M4 x 12	0.18
14	160	40	34	50	39.1	M5 x 16	0.27
15	180	50	34	50	39.1	M5 x 16	0.27
16	200	60	34	50	39.1	M5 x 16	0.26
19	300	90	42	65	48.2	M6 x 18	0.52
20	350	100	42	65	48.2	M6 x 18	0.52
25	400	110	45	75	50.8	M6 x 18	0.62
30	475	150	53	83	58.1	M6 x 18	0.92
35	1100	330	67	95	74.1	M8 x 25	1.88
40	1325	400	77	108	83.4	M8 x 25	2.71
50	2250	688	85	124	93.2	M10 x 25	3.52

- › Wear- and maintenance-free
- › Max. rotational speed: 4000 rpm
- › Temperature range: -40 °C to +175 °C
- › On request: other dimensions, design with keyway according to DIN 6885

CLAMP COUPLINGS DIN 115 / FORM A

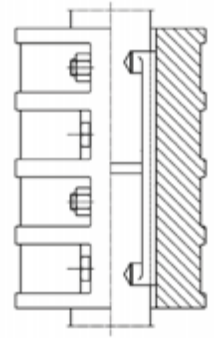
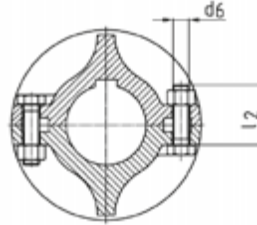
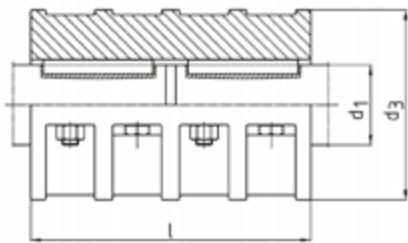

Size d_1	Tolerance ²⁾	Torque $T_{max. Nm}$		Max. rotational speed $n_{max. rpm}$		Moments of inertia kgm^2		Weight kg		d_3 mm	l mm
		EN-GJL	GS	EN-GJL	GS	EN-GJL	GS	EN-GJL	GS		
20	V 7	25	63	1700	1700	0.00093	0.0010	1.9	2.1	85	100
25	V 7	40	100	1500	1500	0.0034	0.0037	4.5	4.9	100	130
30	V 7	60	160	1500	1500	0.0034	0.0036	4.2	4.5	100	130
35	V 7	80	200	1420	1420	0.0066	0.0071	6.5	7.0	110	160
40	V 7	100	250	1420	1420	0.0065	0.0070	6.2	6.7	110	160
45	V 7	125	315	1350	1350	0.011	0.012	8.5	9.2	120	190
50	V 7	150	400	1300	1300	0.014	0.016	9.0	9.7	130	190
55	U 7	500	1600	1200	1200	0.026	0.028	13	14	150	220
60	U 7	850	1800	1200	1200	0.025	0.027	12.5	13.5	150	220
65	U 7	1250	2000	1120	1120	0.051	0.055	18.5	20	170	250
70	U 7	1700	2240	1120	1120	0.050	0.054	17	18	170	250
75 ¹⁾	U 7	2000	3150	1060	1060	0.107	0.116	28	30	190	280
80	U 7	2500	3550	1060	1060	0.106	0.114	27	29	190	280
90	U 7	3800	5000	1000	1000	0.203	0.219	41	44	215	310
100	U 7	5400	8000	920	920	0.399	0.431	63	68	250	350
110	U 7	7500	10000	920	920	0.467	0.505	70	76	250	390
120	U 7	11000	16000	870	870	0.771	0.832	96	104	275	430
125	U 7	11000	16000	870	870	0.759	0.820	93	100	275	430
140	U 7	15000	22400	800	800	1.63	1.76	160	173	325	490
160	U 7	23000	31500	750	750	2.84	3.07	255	275	365	560
180	U 7	32000	40000	690	690	5.42	5.86	320	346	420	630
200	U 7	40000	56000	630	630	12.02	12.98	550	594	500	700
220 ¹⁾	U 7	50000	80000	580	580	30.78	33.24	840	907	540	770

1) Not included in DIN 115

2) Hole tolerance field for shaft tolerance ISO h9

CLAMP COUPLINGS DIN 115 / FORM A

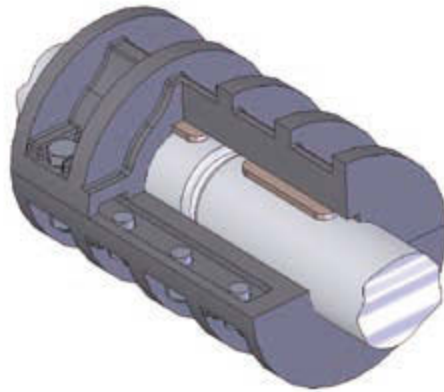

Size	Hexagon-head fitting bolts to DIN EN ISO 4014		Feather key length	Suspension key axial load max. kN
	d_6	l_2 number		
20	M10 x 30	4	-	-
25	M12 x 40	4	-	5
30	M12 x 40	4	-	5
35	M12 x 50	6	-	8
40	M12 x 50	6	-	12
45	M12 x 50	6	-	16
50	M12 x 50	6	-	16
55	M16 x 55	6	100	20
60	M16 x 55	6	100	24
65	M16 x 55	6	100	24
70	M16 x 55	6	110	30
75 ¹⁾	M16 x 60	8	125	37
80	M16 x 75	8	125	37
90	M16 x 90	8	140	42
100	M20 x 90	8	160	55
110	M20 x 90	8	160	55
120	M24 x 90	10	200	70
125	M24 x 90	10	200	70
140	M27 x 110	10	200	90
160	M27 x 110	12	250	110
180	M27 x 130	12	280	-
200	M30 x 140	12	320	-
220 ¹⁾	M36 x 150	12	360	-

1) Not included in DIN 115

CLAMP COUPLINGS DIN 115 / FORM C

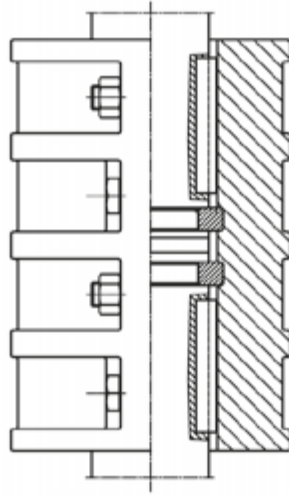

Size d_1	Tolerance ²⁾	Torque $T_{max.}$ Nm		Max. rotational speed $n_{max.}$ rpm		Moments of inertia kgm ²		Weight kg		d_3 mm	l mm
		EN-GJL	GS	EN-GJL	GS	EN-GJL	GS	EN-GJL	GS		
25	V 7	40	100	1420	1420	0.0066	0.0071	7.0	7.5	110	160
30	V 7	60	160	1420	1420	0.0065	0.0070	6.8	7.3	110	160
35	V 7	80	200	1350	1350	0.011	0.012	9.3	10.0	120	190
40	V 7	100	250	1300	1300	0.014	0.016	9.9	10.7	130	190
45	V 7	125	315	1200	1200	0.026	0.028	14.2	15.3	150	220
50	V 7	150	400	1200	1200	0.025	0.027	13.8	14.8	150	220
55	U 7	500	1600	1120	1120	0.051	0.055	20.1	21.6	170	250
60	U 7	850	1800	1120	1120	0.050	0.054	18.7	20.1	170	250
65	U 7	1250	2000	1060	1060	0.107	0.116	30.0	32.3	190	280
70	U 7	1700	2240	1060	1060	0.106	0.114	29.2	31.4	190	280
75 ¹⁾	U 7	2000	3150	1000	1000	0.203	0.219	45.1	48.5	215	310
80	U 7	2500	3550	1000	1000	0.203	0.219	43.7	47.0	215	310
90	U 7	3800	5000	920	920	0.399	0.431	66.4	71.4	250	350
100	U 7	5400	8000	920	920	0.467	0.505	74.3	79.9	250	390
110	U 7	7500	10 000	870	870	0.771	0.832	101.0	108.7	275	430
120	U 7	11000	16 000	800	800	1.63	1.76	173.5	186.7	325	490
125	U 7	11000	16 000	800	800	1.63	1.76	170.1	183.0	325	490
140	U 7	15000	22 400	750	750	2.84	3.07	272.5	293.2	365	560
160	U 7	23000	31500	690	690	5.42	5.86	342.4	368.4	420	630
180	U 7	32000	40 000	630	630	12.02	12.98	577.0	620.8	500	700
200 ¹⁾	U 7	40 000	56 000	580	580	30.78	33.24	871.8	937.9	540	770

1) Not included in DIN 115

2) Hole tolerance field for shaft tolerance ISO h9

CLAMP COUPLINGS DIN 115 / FORM C

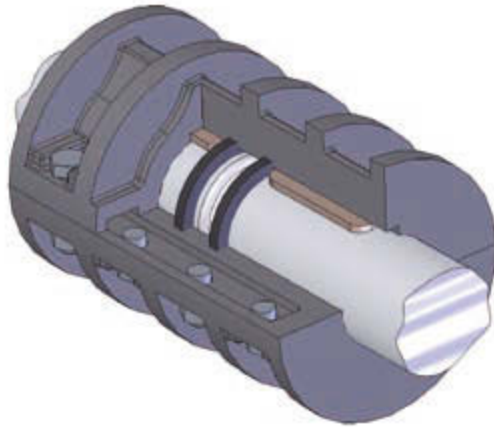

Size d_1	Hexagon-head fitting bolts to DIN EN ISO 4014		Feather key length	Maximum lateral load on insert ring max. kN
	d_6 l_2	number		
25	M12 x 50	6	56	12
30	M12 x 50	6	56	17
35	M12 x 50	6	70	23
40	M12 x 50	6	70	30
45	M16 x 55	6	80	36
50	M16 x 55	6	80	45
55	M16 x 55	6	90	53
60	M16 x 55	6	90	62
65	M16 x 60	8	100	72
70	M16 x 60	8	100	82
75 ¹⁾	M20 x 75	8	110	92
80	M20 x 75	8	110	105
90	M20 x 90	8	125	135
100	M24 x 90	8	140	165
110	M24 x 90	10	160	200
120	M27 x 110	10	180	250
125	M27 x 110	10	180	250
140	M27 x 110	12	200	310
160	M27 x 130	12	220	400
180	M30 x 140	12	250	500
200 ¹⁾	M36 x 150	12	280	600

1) Not included in DIN 115

FLANGE COUPLINGS DIN 116

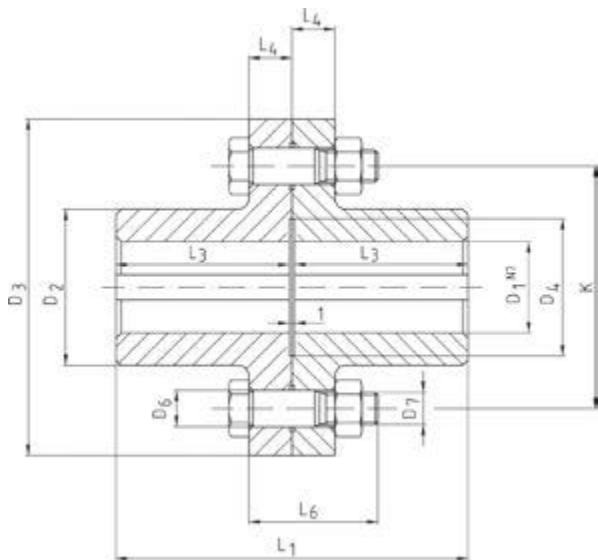

Form A

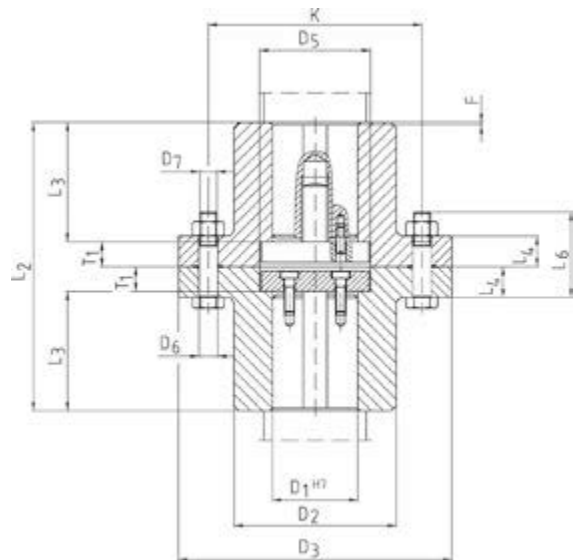

Form C

Size	D ₂	D ₃	D ₄	D ₅	D ₆ (H7)	K	L ₁	L ₂	L ₃ ²⁾	L ₄	F ³⁾	T ₁	Hexagon-head fitting bolts to DIN 609		
													D ₇	L ₆	number
25	58	125	40	45	11	90	101	117	50	16	1	8.5	M10	45	3
30	58	125	40	45	11	90	101	117	50	16	1	8.5	M10	45	3
35	72	140	50	55	11	100	121	141	60	16	1	10.5	M10	45	3
40	72	140	50	55	11	100	121	141	60	16	1	10.5	M10	45	3
45	95	160	60	65	11	125	141	169	70	18	1	14.5	M10	50	3
50	95	160	60	65	11	125	141	169	70	18	1.6	14.5	M10	50	3
55	110	180	70	75	13	140	171	203	85	18	1.6	16.5	M12	50	4
60	110	180	70	75	13	140	171	203	85	18	1.6	16.5	M12	50	4
70	130	200	80	85	13	160	201	233	100	23	1.6	16.5	M12	60	6
80	145	224	90	95	13	180	221	261	110	23	1.6	20.5	M12	60	8
90	164	250	100	105	17	200	241	281	120	30	2.5	20.5	M16	80	8
100	180	280	110	120	17	224	261	301	130	30	2.5	20.5	M16	80	8
110	200	300	120	130	17	250	281	329	140	33	2.5	24.5	M16	85	8
120	225	335	135	145	17	280	311	359	155	33	2.5	24.5	M16	85	10
125	225	335	135	145	17	280	311	359	155	33	4	24.5	M16	85	10
140	250	375	150	160	21	310	341	397	170	40	4	28.5	M20	100	10

- 1) Grooves according to DIN 6685/1; tolerance zone JS9
- 2) Tolerance of hub length: L₃ ≤ 120: +0.3 and L₃ > 120: +0.5 respectively
- 3) Bevel F x 45°

TECHNICAL DATA

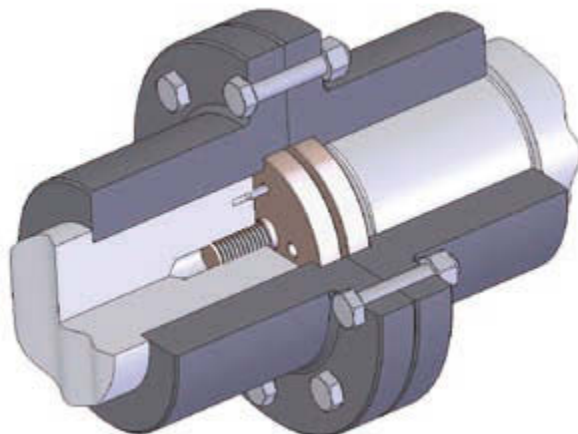

Form C

Size	Torque		Max. rotational speed		Moments of inertia ³⁾		Weight ³⁾		Moments of inertia ³⁾		Weight ³⁾	
	T _{max.} Nm		n _{max.} rpm		Form A		Form A		Form C		Form C	
	D ₁ ⁴⁾	EN-GJL ¹⁾	GS ²⁾⁵⁾	EN-GJL	GS ⁵⁾	EN-GJL	GS ⁵⁾	EN-GJL	GS ⁵⁾	EN-GJL	GS ⁵⁾	EN-GJL
25	46.2	69	4600	6850	0.0062	0.0067	3.9	4.2	0.0063	0.0068	4.0	4.3
30	87.5	131	4600	6850	0.0062	0.0067	3.7	4.0	0.0062	0.0067	3.8	4.1
35	150	225	4100	6150	0.0105	0.0113	5.4	5.8	0.0107	0.0116	5.7	6.1
40	236	354	4100	6150	0.0104	0.0112	5.2	5.5	0.0106	0.0115	5.4	5.8
45	355	533	3600	5350	0.023	0.025	9.1	10.0	0.024	0.026	9.8	10.6
50	515	773	3600	5350	0.023	0.024	8.7	9.4	0.024	0.026	9.5	10.2
55	730	1095	3200	4750	0.041	0.044	13.1	14.2	0.043	0.047	14.3	15.5
60	975	1463	3200	4750	0.040	0.043	12.6	13.6	0.043	0.046	13.7	14.8
70	1700	2550	2850	4300	0.082	0.088	20.0	21.6	0.087	0.094	21.8	23.5
80	2650	3975	2550	3850	0.134	0.144	26.4	28.5	0.144	0.155	29.1	31.4
90	4120	6180	2300	3450	0.257	0.276	38.7	41.8	0.274	0.295	42.3	45.7
100	5800	8700	2050	3050	0.404	0.435	49.8	53.7	0.428	0.461	53.8	58.2
110	8250	12375	1900	2850	0.608	0.652	64.1	68.9	0.652	0.699	70.4	75.7
120	11200	16800	1700	2550	1.011	1.085	88.2	94.7	1.084	1.163	96.3	103.4
125	12800	19200	1700	2550	1.003	1.076	86.0	92.4	1.075	1.154	102.1	109.7
140	19000	28500	1550	2300	1.81	1.93	121	130	1.93	2.07	133	142

1) Max. torque based on DIN 116 Hole tolerance zone:

Form A: ISO H7 - for shaft tolerance ISO h9

Form C: ISO N7 - for shaft tolerance ISO k6 and m6 respectively

Other hole tolerances can be agreed when ordering.

2) Max. torques (for hole D1) with allowable load on the feather key and with average overdimension of the following tolerance zones:

For D1 ≤ 50: ISO N7 - for shaft tolerance ISO k6

For D1 > 50: ISO N7 - for shaft tolerance ISO m6

3) Figures for moments of inertia and weights for hole D1 (in the case of form C without axial thrust washer)

4) Couplings for D1 = 260 to 500 mm are not included in DIN 116.

5) Couplings up to size 100 of steel

FLANGE COUPLINGS DIN 116

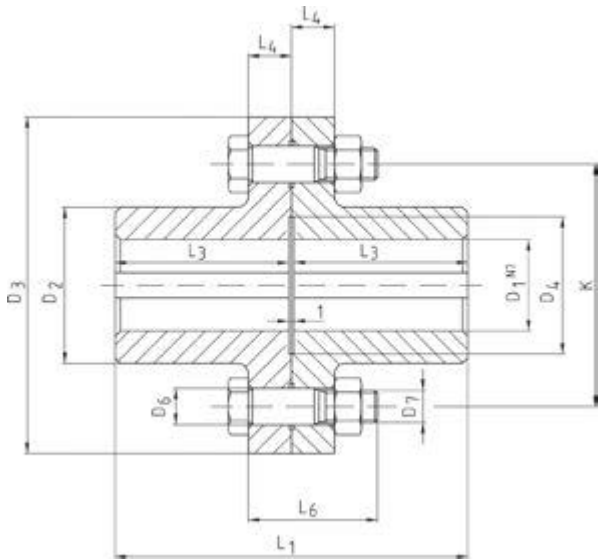

Form A

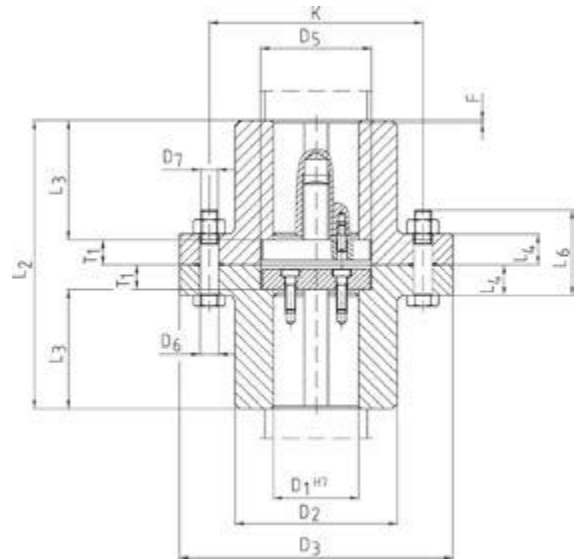

Form C

Size	D ₂	D ₃	D ₄	D ₅	D ₆ H7	K	L ₁	L ₂	L ₃ ²⁾	L ₄	F ³⁾	T ₁	Hexagon-head fitting bolts to DIN 609		
													D ₇	L ₆	number
160	290	425	240	180	25	350	401	457	200	40	4	28.5	M24	110	10
180	325	450	265	212	25	380	451	507	225	45	4	28.5	M24	120	12
200	360	500	290	232	25	420	501	557	250	45	6	28.5	M24	120	16
220	400	560	310	252	32	470	541	597	270	52	6	28.5	M30	140	14
250	450	630	390	282	32	540	601	657	300	52	6	28.8	M30	140	16
260	500	710	420	302	32	600	681	741	340	55	6	30.5	M30	150	16
280	500	710	420	322	32	600	681	741	340	55	6	30.5	M30	150	16
300	560	750	460	352	38	640	761	831	380	62	10	35.5	M36	170	16
320	560	750	460	372	38	640	761	831	380	62	10	35.5	M36	170	16
340	650	900	520	392	44	760	881	961	440	70	10	40.5	M42	190	14
360	650	900	520	412	44	760	881	961	440	70	10	40.5	M42	190	14
380	720	1000	600	442	44	850	1001	1091	500	70	10	45.5	M42	190	16
400	720	1000	600	462	44	850	1001	1091	500	70	10	45.5	M42	190	16
420	800	1060	650	482	50	920	1161	1251	580	80	10	45.5	M48	220	16
450	800	1060	650	512	50	920	1161	1251	580	80	10	45.5	M48	220	16
460	900	1180	800	532	50	1030	1321	1421	660	90	10	50.5	M48	240	20
500	900	1180	800	572	50	1030	1321	1421	660	90	16	50.5	M48	240	20

- 1) Grooves according to DIN 6685/1; tolerance zone JS9
- 2) Tolerance of hub length: L₃ ≤ 120: +0.3 and L₃ > 120: +0.5 respectively
- 3) Bevel F x 45°

CLAMP / FLANGE

TECHNICAL DATA

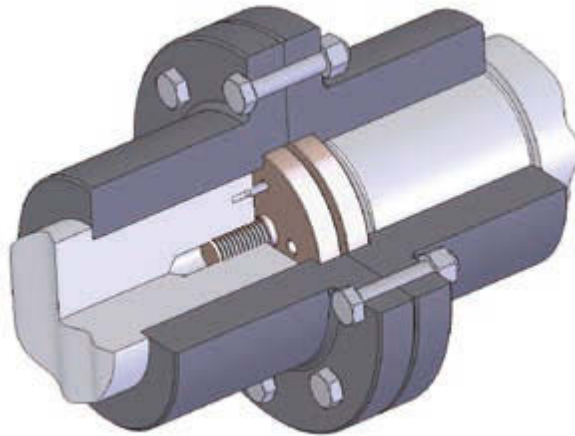

Form C

Size	Torque		Max. rotational speed		Moments of inertia ³⁾		Weight ³⁾		Moments of inertia ³⁾		Weight ³⁾	
	T_{max} Nm		n_{max} rpm		Form A		Form A		Form C		Form C	
$D_1^{4)}$	EN-GJL ¹⁾	GS ²⁾⁵⁾	EN-GJL	GS ⁵⁾	EN-GJL	GS ⁵⁾	EN-GJL	GS ⁵⁾	EN-GJL	GS ⁵⁾	EN-GJL	GS ⁵⁾
					kgm ²		kg		kgm ²		kg	
160	30700	46050	1350	2000	3.39	3.63	181	194	3.63	3.89	197	212
180	45000	67500	1250	1900	5.30	5.68	242	259	5.67	6.07	261	280
200	61500	92250	1150	1700	8.58	9.19	322	346	9.14	9.79	347	372
220	82500	123750	1000	1550	14.87	15.92	444	476	16.00	17.14	485	521
250	118000	177000	900	1350	25.29	27.09	605	649	26.69	28.59	644	692
260	136000	204000	800	1200	44.09	47.28	877	942	46.42	49.79	932	1001
280	170000	255000	800	1200	43.32	46.46	835	897	45.55	48.85	886	951
300	206000	309000	750	1150	70.10	75.14	1163	1248	74.26	79.61	1239	1330
320	250000	375000	750	1150	68.81	73.74	1109	1191	72.77	78.01	1179	1266
340	300000	450000	650	950	155.03	166.24	1874	2013	163.89	175.77	1997	2146
360	355000	532500	650	950	152.88	163.93	1804	1937	161.43	173.13	1920	2062
380	425000	637500	550	850	255.02	273.58	2545	2733	269.85	289.55	2711	2913
400	487000	730500	550	850	251.63	269.94	2457	2639	265.99	285.39	2613	2807
420	560000	840000	550	800	420.01	450.49	3552	3814	442.88	475.09	3762	4040
450	710000	1065000	550	800	411.84	441.69	3378	3628	433.75	465.27	3574	3838
460	750000	1125000	500	750	755.07	810.06	5156	5538	796.31	854.42	5458	5864
500	950000	1425000	500	750	738.28	792.00	4866	5226	777.58	834.27	5142	5524

1) Max. torque based on DIN 116 Hole tolerance zone:

Form A: ISO H7 - for shaft tolerance ISO h9

Form C: ISO N7 - for shaft tolerance ISO k6 and m6 respectively

Other hole tolerances can be agreed when ordering.

2) Max. torques (for hole D1) with allowable load on the feather key and with average overdimension of the following tolerance zones:

For $D1 \leq 50$: ISO N7 - for shaft tolerance ISO k6

For $D1 > 50$: ISO N7 - for shaft tolerance ISO m6

3) Figures for moments of inertia and weights for hole D1 (in the case of form C without axial thrust washer)

4) Couplings for $D1 = 260$ to 500 mm are not included in DIN 116.

5) Couplings up to size 100 of steel

Tecnamic GmbH & Co. KG

Kleinbahnstraße 21
59759 Arnsberg
Germany

T +49 2932 300-440

F +49 2932 300-830

E info@tecnamic.com



TECNAMIC

www.tecnamic.com