

DESCH Planox® - PH

Hydraulically actuated friction clutches

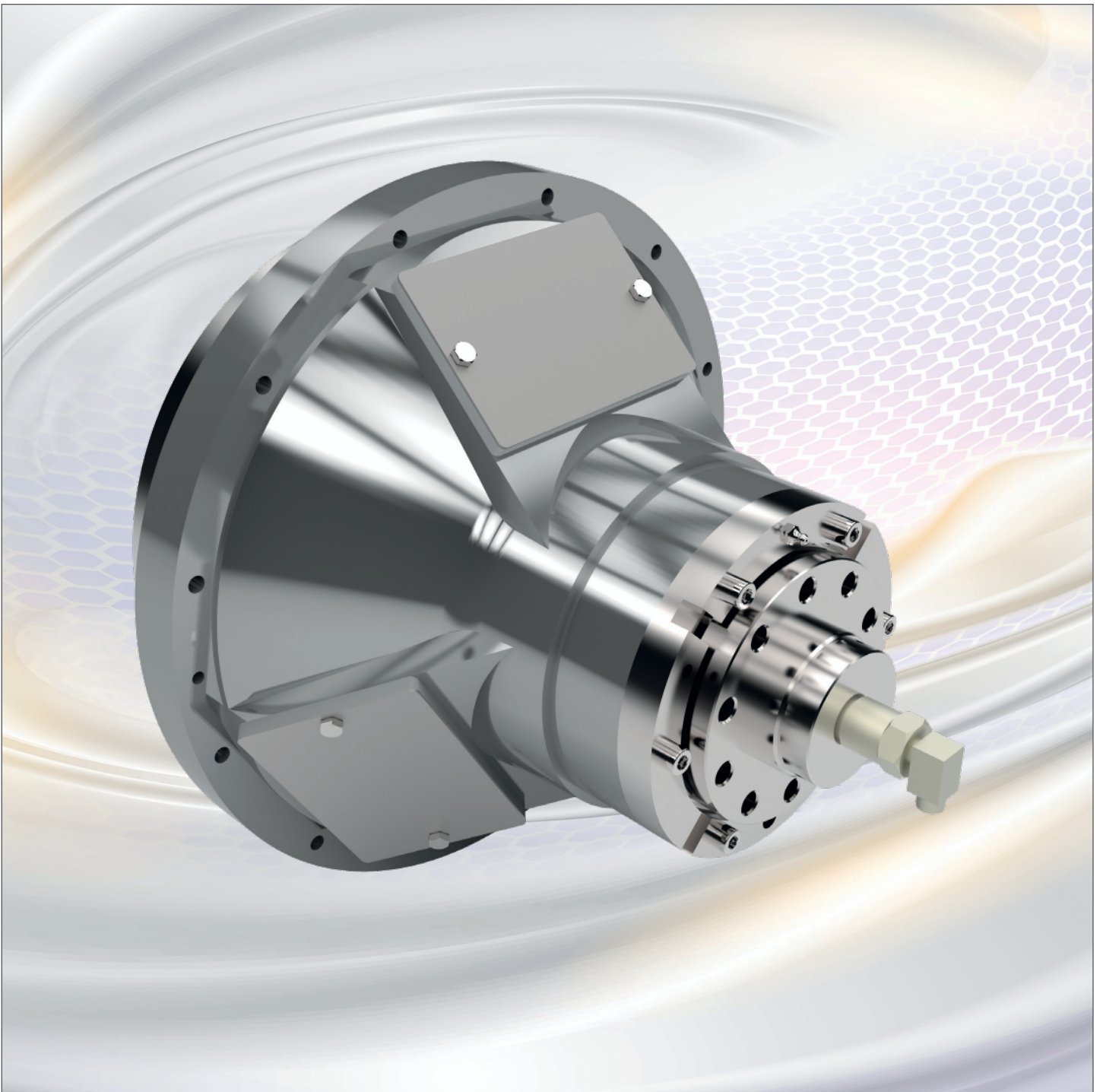

Example of hydraulic actuating device

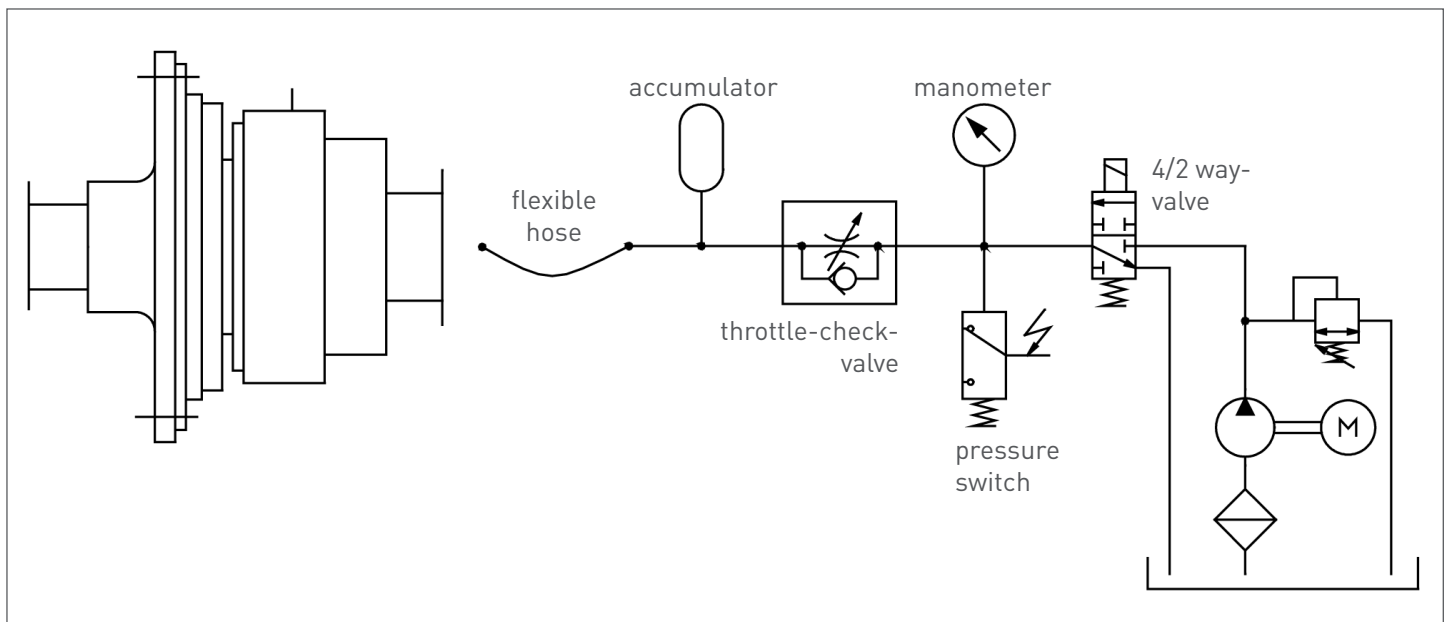

The hydraulic control of the clutch in the example consists of a 4/2-way-valve, an adjustable throttle-check-valve and an accumulator. A manometer and pressure switch are used for pressure monitoring. The clutch is connected to the hydraulic unit by a rotary union and a short flexible hose.

To ensure a smooth engagement, the pressure build-up can be controlled via the throttle-check-valve. The accumulator is used to absorb pressure peaks and adjust pressure fluctuations. For disengagement the oil is to be led back pressure free into the tank.

DESCH Planox® - PH friction clutches

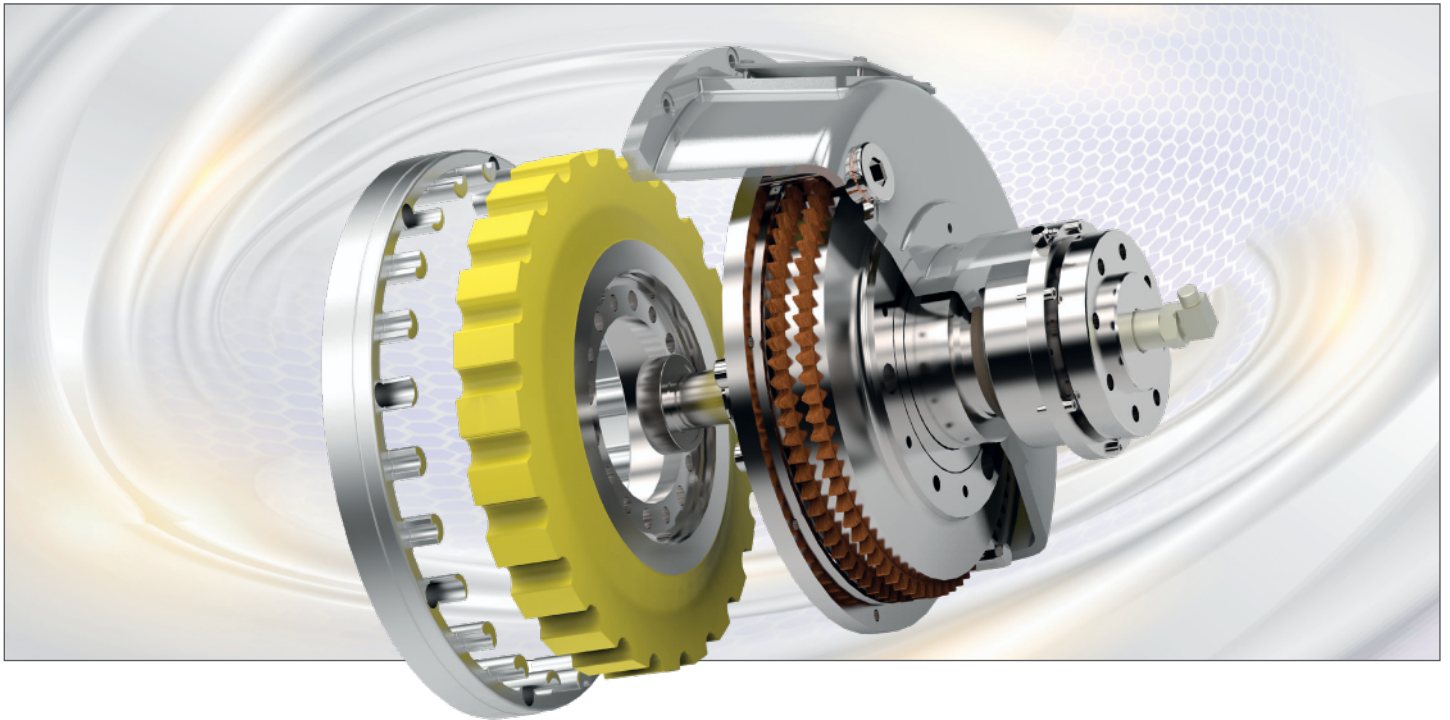

DESCH Planox® friction clutch
Type PH - 142/1-SZ with highly flexible coupling

Function

The DESCH Planox® friction clutches are engageable respective disengageable dry-friction clutches which transmit torque by friction.

These clutches permit rapid acceleration of the driven machines or machinery groups as well as reliable torque transmission. Machines connected with friction clutches are protected against damage which can occur through peak torques during operation or during the engaging/disengaging process.

Hydraulically actuated

Hydraulically actuated Planox® clutches, type PH, have the design and mode operation as the pneumatically actuated Planox® clutches.

The oil is supplied axially by a rotary union. The torque indicated in the list is configured for an oil pressure of 35 bar.

Special ventilation springs enable safe operation even when the machine is inclined. All versions of the clutch can be equipped with an additional flexible clutch for reducing the torsional vibrations. For the use of hydraulic pumps, we provide complete drive units comprised of pump drive and Planox® clutch.

Technology

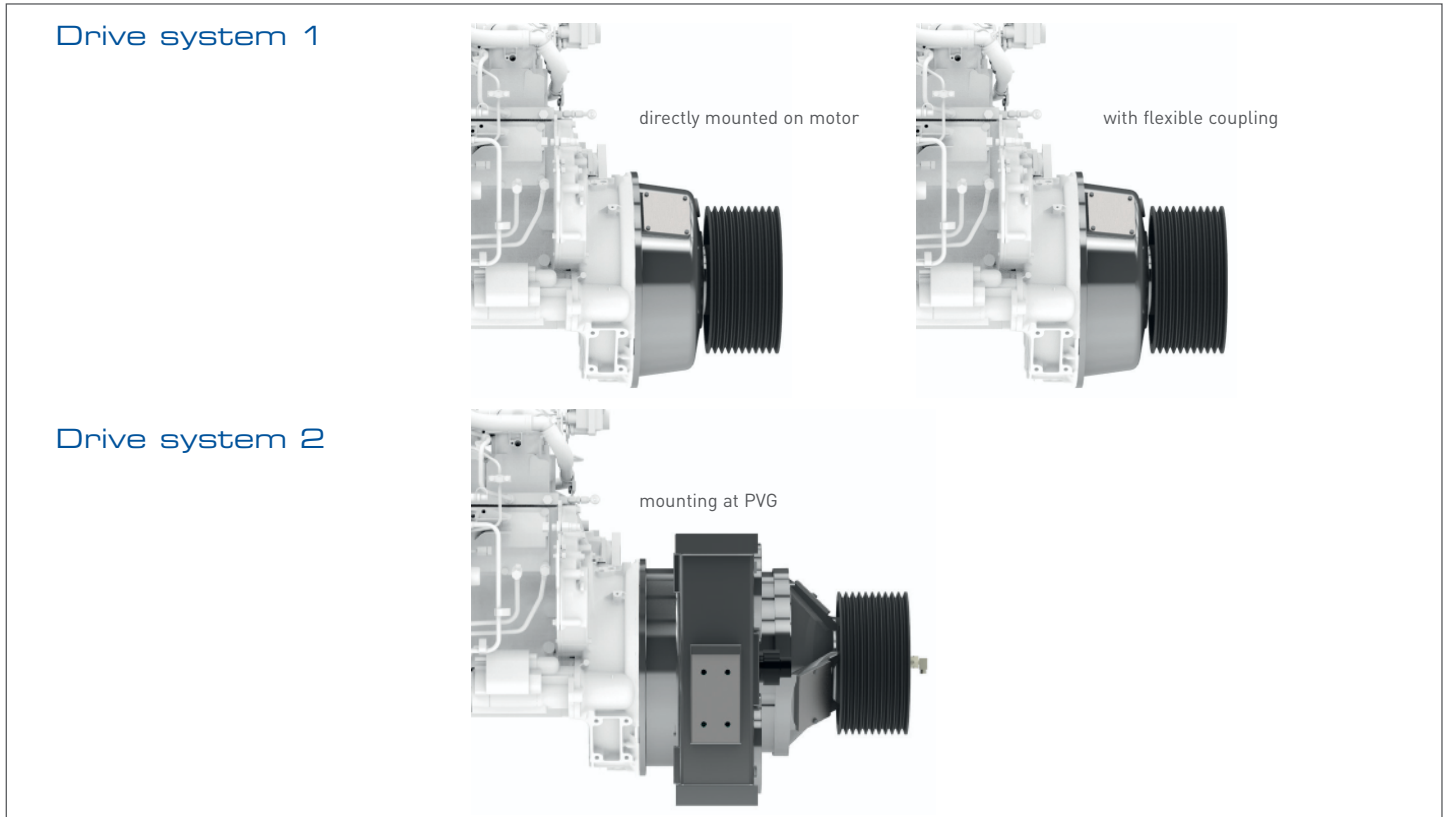

Examples



Road Milling Machine



Crusher



Shredder

Technical Data

size	torque T_0 at 35 bar Nm	max. speed rpm	need of oil per actuation		Anschlussmaß	
			with new	with worn	SAE J 617 housing size	SAE J 620d, J 621 flywheel size
			friction discs	friction discs		
liter	liter					
81	765	3200	0,021	0,039	5-4-3	8"
101	1260	3000	0,035	0,064	4-3-2-1	10"
111	1420	2850	0,035	0,064	4-3-2-1	11½"
112	2870	2850	0,035	0,092	3-2-1-0	11½"
113	4240	2850	0,035	0,092	3-2-1-0	11½"
142	5240	2500	0,058	0,145	1-0-00	14"
143	7500	2500	0,058	0,189	1-0-00	14"
163	11100	2200	0,073	0,279	0-00	16"
183	13600	1960	0,080	0,308	0-00	18"
213	17300	1600	0,087	0,398	00	21"

Measurements under operating conditions

Reduction of torsial vibrations using a combination of Planox® clutch and flexible coupling.

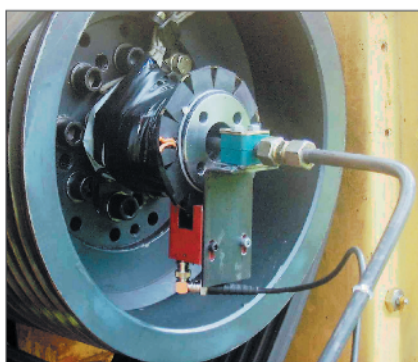

Measurement of vibration and torque through telemetry at side

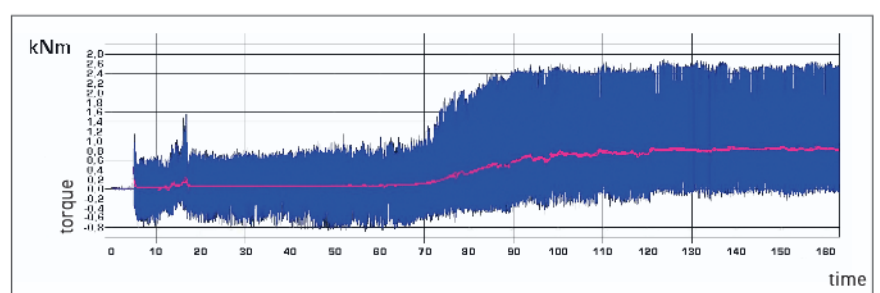

Torsional vibrations measured without flexible coupling.

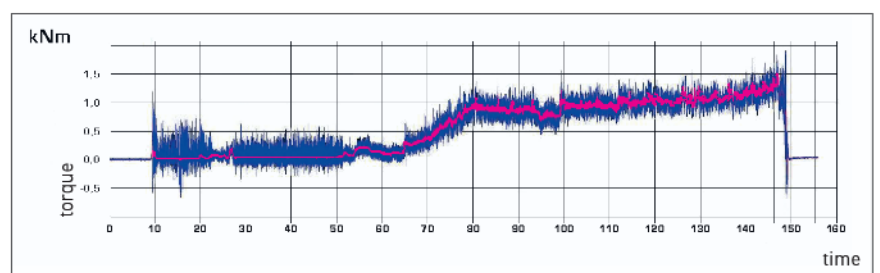

Torsional vibrations measured with flexible coupling.

CONTACT

DESCH Antriebstechnik GmbH & Co. KG
Postbox 1440
59753 Arnsberg/Germany
Kleinbahnstraße 21
59759 Arnsberg/Germany
T +49 2932 300 0
F +49 2932 300 899
info@desch.com
www.desch.com



DESCH Canada Ltd.
240 Shearson Crescent
Cambridge
Ontario
Canada N 1T 1J6
T +1800 2631866
+1519 6214560
desch.canada@desch.com

DESCH USA LP
Sales, Engineering,
Service Support
3501 Embassy
Parkway, Suite 101
Akron Ohio 44333
T +1 330 937 9030
F +1 330 937 9031
sales_usa@desch.com

DESCH USA LP
Manufacturing,
Assembly
4940 Merrifield Rd
Dallas
Texas 75236
desch.dallas@desch.com

DESCH Italy
Drive Technology
Ufficio di rappresentanza
in Italia
Via Cavriana, 3
20134 Milano/Italy
T +39 02 7391 280
F +39 02 7391 410
desch.italia@desch.com

DESCH China
Machinery (Pinghu) Co., Ltd.
No. 1680 Xingping 1 Road, Build. 3
Pinghu Economic Technological
Development Zone
314200 Zhejiang P. R. China
T +86 573 8557 8988
F +86 573 8557 8989
desch.china@desch.com

DESCH do Brasil
Power Transmission S.A.
Rdv Edgar Máximo
Zambotto, s/n km 54
Campo Limpo Paulista, SP
CEP: 13.231-700
T +55 11 4039 8240
F +55 11 4039 8222
desch.brasilien@desch.com